

ProteCol™

a revolution in Capillary LC

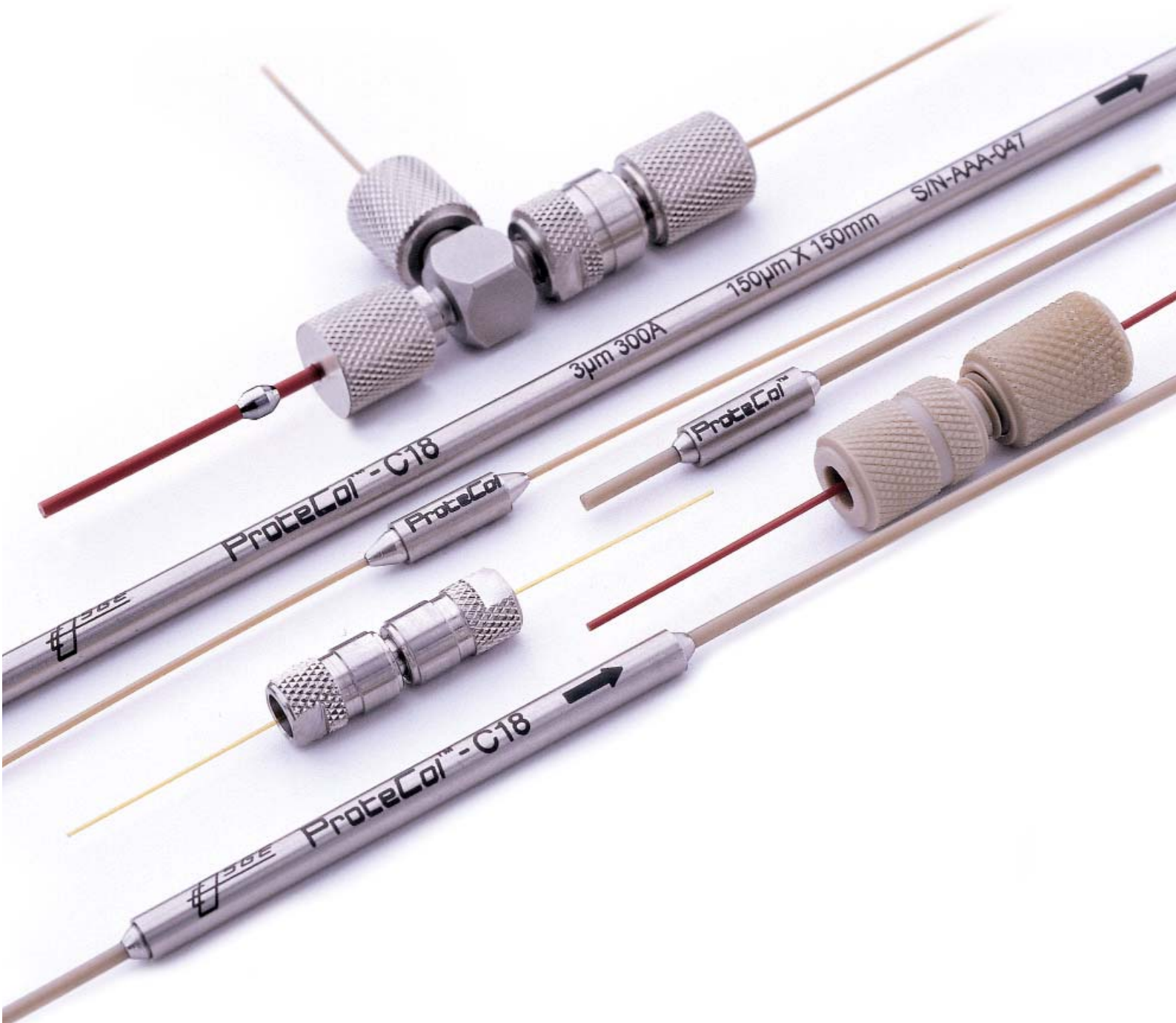

CAPILLARY LC

THE ProteCol™ SYSTEM

Incorporating columns, unions, tubing, splitters and filters, every component of ProteCol has been designed specifically for Capillary LC.

• **Performance Plus:** The peak broadening effect of dead volume and total swept volume is much more significant in Capillary LC compared to conventional LC. The entire ProteCol range has been specifically designed as a 'zero dead volume' system to give you the highest possible resolution and efficiency, therefore maximizing the advantages of Capillary LC

- **Ease of Use:** A key to the success of the ProteCol system is the ease with which zero dead volume connections can be made between columns, tubing and all accessories
- **Versatility:** ProteCol columns, unions and accessories are designed to be used together as a complete system, or can be individually incorporated into your existing capillary LC setup
- **Flexibility:** With a variety of columns, unions, and tubing sizes, ProteCol adapts to suit your own requirements

YOUR FLEXIBLE CAPILLARY LC SYSTEM

ProteCol can provide you with a complete Capillary LC solution, or individual components of ProteCol can be incorporated into your existing system.

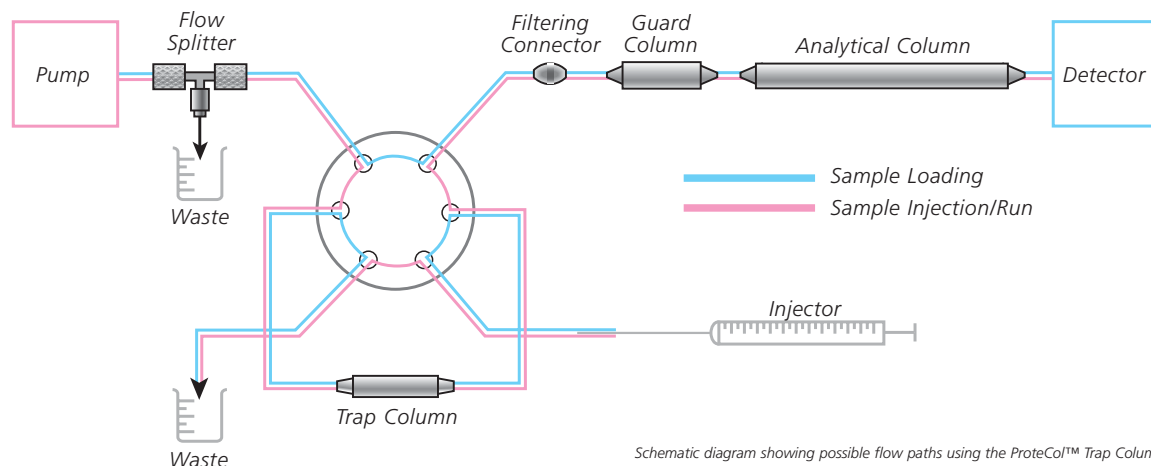

MAXIMUM PERFORMANCE

The core of any separation system is the column. ProteCol columns are designed specifically for Capillary LC. The column body is integrated with the connection tubing, both of which are made from inert fused silica lined PEEK™ tubing, giving a robust and flexible column.

The connection tubing is available in 1/16" and 1/32" outer diameter, and is supplied with precisely square cut and polished ends for easy zero dead volume connections. To minimize post column broadening, ProteCol columns are supplied with a short 100mm outlet tail.

ProteCol columns are available in a variety of lengths, ID's and packings.

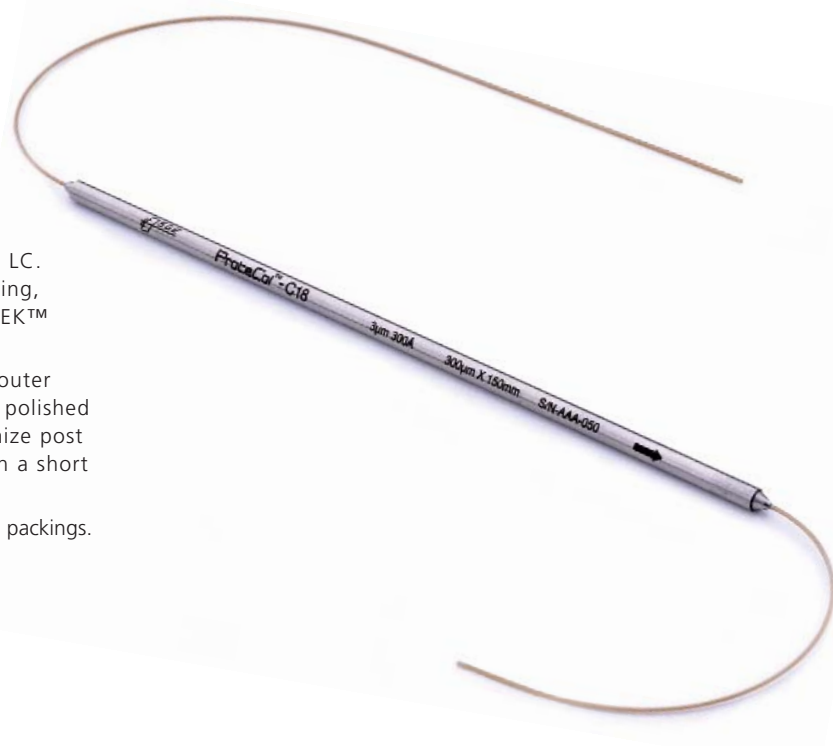

MAKE THE PERFECT CONNECTION

The effect of any dead volume is significantly more detrimental to peak shapes and resolution in Capillary LC compared to conventional LC and even micro-LC.

ProteCol™ Unions are specially designed and manufactured to exacting tolerances and provide perfect butt connections with zero dead volume. Maximum performance is delivered when using the ProteCol Unions with PEEKsil™ tubing which has perfectly square cut and polished ends.

Available in stainless steel and PEEK™, the range of ProteCol Unions and reusable PEEK ferrules allows you to connect any combination of 1/32" PEEKsil, 1/16" PEEKsil and 0.36mm fused silica tubing.

The stainless steel unions can be wrench-tightened for operation at high pressures, whereas the PEEK unions allow for easy finger tightening and have the advantage of being lighter than stainless steel.

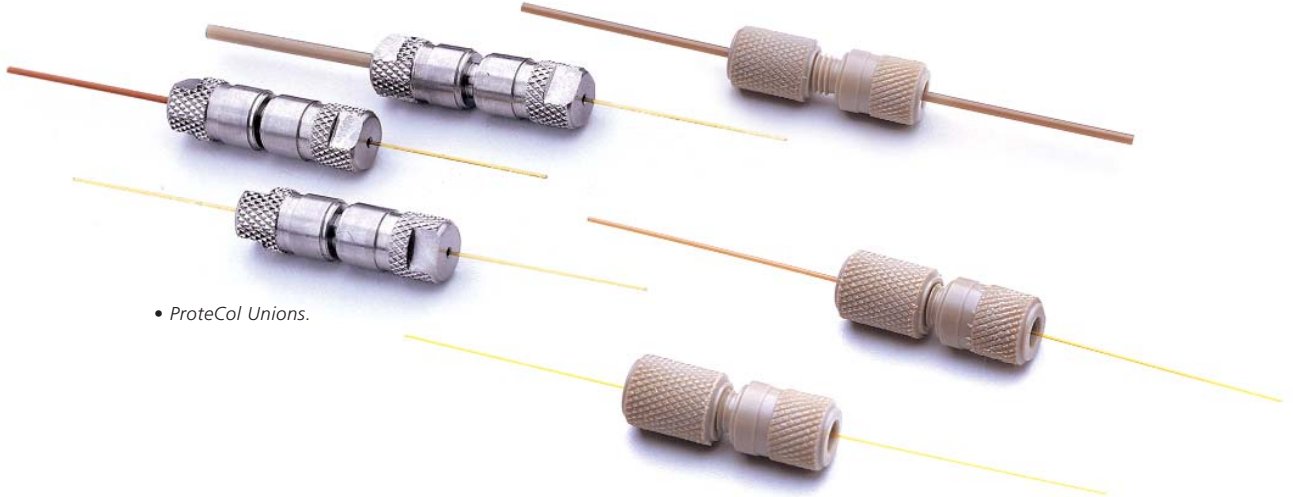

• ProteCol Unions.

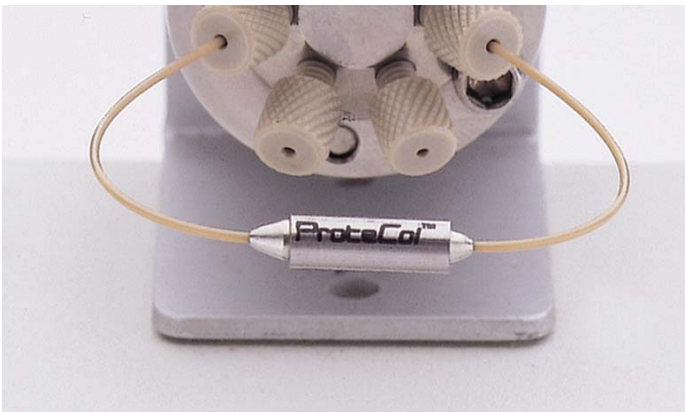

• ProteCol Trap Column.

INCREASED SENSITIVITY

ProteCol Trap columns allow an on-line pre-concentration or the desalting of a sample before injection into the analytical column. Typically connected to the injector as shown, all trap columns come with 1/32" PEEKsil tails for maximum flexibility. SGE also supplies a PEEK adaptor nuts to connect the 1/32" tails into the common 10/32 injector seats.

GUARD YOUR INVESTMENT

ProteCol Guard Columns protect and maintain the integrity of the analytical column from the effects of chemical and particulate contaminants. These contaminants can alter the analytical column's characteristics; these can be reflected in a multitude of symptoms including peak tailing, peak splitting, high back pressures, reduced efficiency, shifted retention times, poor resolution etc.

By locating a guard column in front of the analytical column, the contaminants are isolated on the guard column, which is easily and cheaply replaced, rather than destroying the expensive analytical column. Use of a guard column can extend the life of an analytical column typically by a factor of 4.



• ProteCol Guard Column

PARTICULATE PROTECTION

The ProteCol In-Line Filter is a simple way of removing any particulates before they reach the column, without introducing peak tailing or loss of resolution.



• ProteCol In-line Filter

PEEKsil™ TUBING - INERT, ROBUST, PRECISION MADE

SGE's PEEKsil tubing is integral to ProteCol performance, and combines the inertness and smooth surface of fused silica for optimum liquid flow, with the easy handling and robustness of PEEK.

The ends of all PEEKsil tubing are perfectly square cut and polished to facilitate zero dead volume connections, critical to the success of Capillary LC.

PEEKsil is manufactured to exacting tolerances of concentricity and bore diameter for reproducible flow rates and reliable connections.

PEEKsil is available in 1/32" and 1/16" OD, and ID's from 25µm to 300µm. A range of standard lengths are available; SGE can also provide custom lengths upon request.



• Conventional PEEK™ tubing as supplied showing a rough cut end resulting in dead volume and a loss in chromatographic performance.

• PEEKsil tubing showing the ground and square cut end enabling a zero dead volume connection.

FLOW SPLITTER

The ProteCol Flow Splitter is a precision engineered static flow splitter that allows the capillary LC columns and components to be used with conventional LC pumping systems. Ideally positioned between the pump and injector, the user can achieve the reliable low flows required by capillary LC, while operating the LC pumping system within its normal operating parameters.



• ProteCol Flow Splitter.



• ProteCol Accessory Kit.

ACCESSORY KIT

ProteCol Accessory Kits provide a selection of PEEKsil tubing, unions, ferrules, an in-line filter, plus a User Guide to connecting ProteCol components. Two kits are available – optimized for 1/16" and 1/32" tubing. This is the ideal starter kit for all new ProteCol users.

SGE is continually developing new ProteCol products. Please visit www.sge.com/protectol for the latest range.

SGE International Pty. Ltd.
Toll Free: 1800 800 167
Tel: +61 (0) 3 9837 4200
Fax: +61 (0) 3 9874 5672
Email: support@sge.com

SGE Europe Ltd (UK)
Tel: (0) 1908 568 844
Fax: (0) 1908 566 790
Email: uk@sge.com

SGE Italia Srl.
Tel: 06 4429 0206
Fax: 06 4429 0724
Email: sge.italia@tin.it

SGE Japan Inc.
Tel: +81 45 222 2885
Fax: +81 45 222 2887
Email: japan@sge.com

SGE China
Tel: +86 (10) 6588 8666
Fax: +86 (10) 6588 6577

SGE, Incorporated (USA)
Tel: (800) 945 6154
Fax: (512) 836 9159
Email: usa@sge.com

SGE (France) Sarl
Tel: +33 (0) 1 6929 8090
Fax: +33 (0) 1 6929 0925
Email: france@sge.com

SGE GmbH (Germany)
Tel: +49 (0) 6151 860486
Fax: +49 (0) 6151 860489
Email: germany@sge.com

SGE India
Tel: +91 (022) 2471 5896
Fax: +91 (022) 2471 6592
Email: sgeindia@vsnl.com

