



Agnieszka Kossakowska

Praha, 03.10.2016

Water Determination by Karl Fischer Titration

Honeywell

Why Water Determination?

Polyols for foams

- Water content defines the properties of the polymer

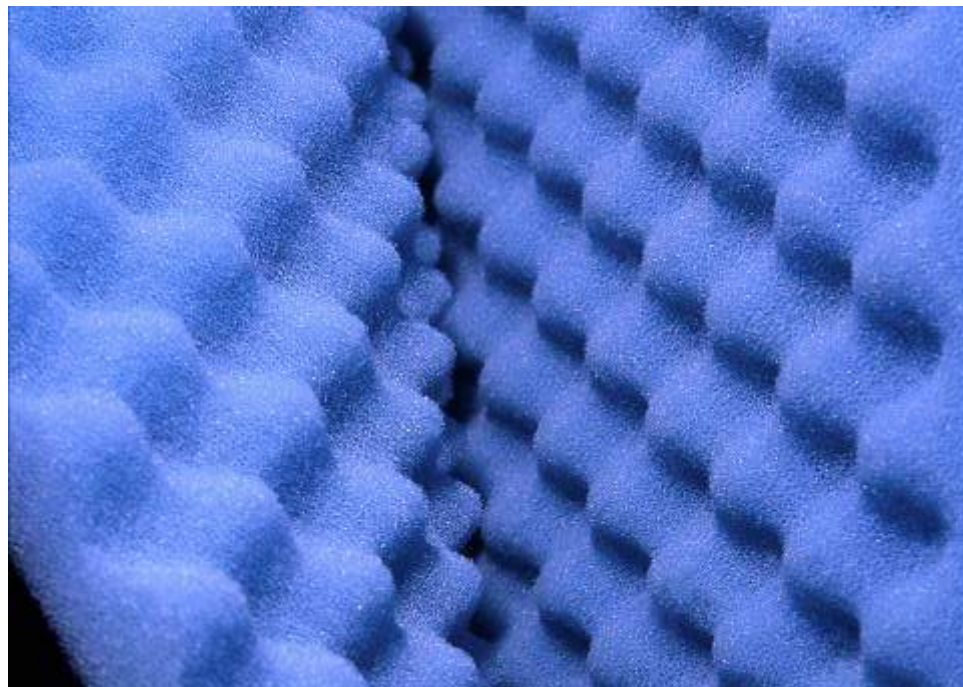

Makes you sleep well!

Why Water Determination?

Fuel, oils and lubricants

- Water content indicates the danger for corrosion

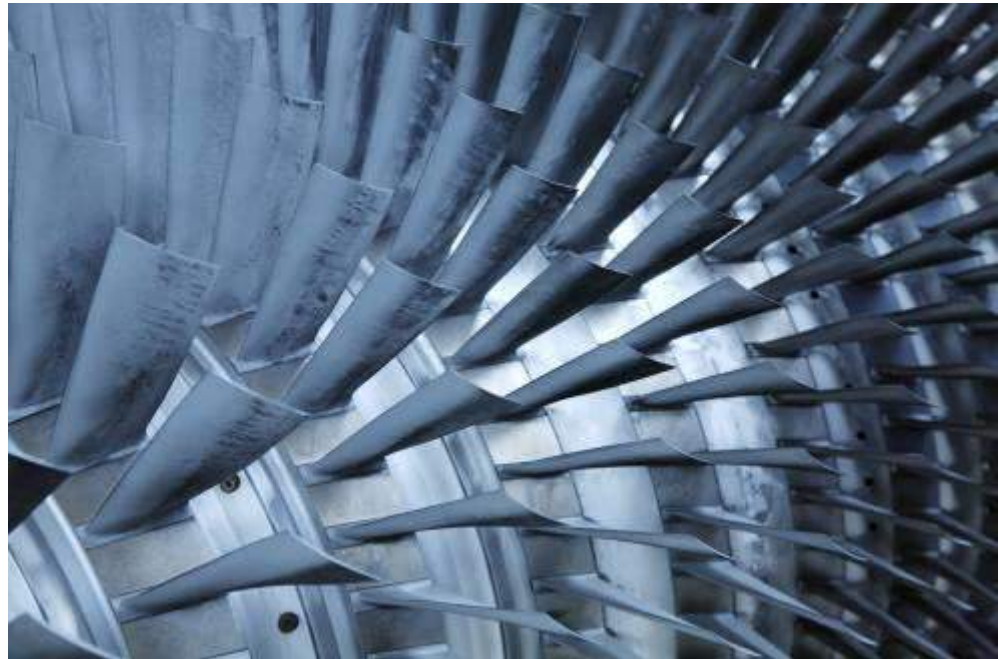

Keeps airplanes safe!

Why Water Determination?

Pharmaceutical products

- Water content defines the quality and shelf life



Avoids headaches!

Applications for Karl Fischer Titration

- Chemical industry
- Pharmaceutical industry
- Petrochemical industry
- Power stations
- Plastic industry
- Feed
- Food and beverage
- Paints, Adhesives
- Cosmetic industry

... *and more*

→ **many different samples!**



P
U
R
P
O
S
E

Product characterization
Quality Control
Cost savings
Safety
Shelf life

Techniques for Moisture/Water Determination

Karl Fischer (KF) titration is the most popular water determination technique!

customer survey 2003

“Is KF your method of choice for water determination?” SIAL survey 2003

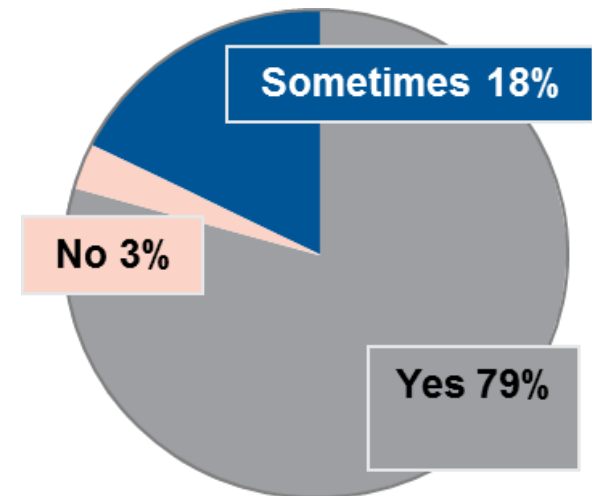

Alternative techniques

- Weight loss upon drying (most common alternative):
Drying cabinet, Microwave drying, Halogen drying, IR drying
- GC/MS
- NIR
- Xylene distillation (DIN ISO 3733)

KF titration is always the reference method!

Moisture/Water Determination

- Types of water:
 - water of crystallization (chemically combined)
 - entrapped water
 - adherent moisture
- To determine water of crystallization and entrapped water, sample must be dissolved completely.
- To determine only adherent moisture, dissolution of the sample must be prevented.

Why Karl Fischer Titration?

- **Selective**: determination of the water content
 - drying techniques cannot differentiate between water and moisture
 - chemically combined water (water of crystallization) may not be detected completely by loss on drying method
- **Accurate**: very small standard deviations are achievable
- **Traceable** to water via the standard used for validation
- **Wide measuring range**: ppm - %
- **Fast**: 1-3 minutes average per determination

History of Karl Fischer Titration

The milestones

- 1935 Karl Fischer published a reagent for water determination consisting of iodine, SO_2 , **pyridine and methanol**
- 1979 Eugen Scholz and Helga Hoffmann, Riedel-de Haën, **replaced pyridine by imidazole** and invented Hydranal reagents
- **1980** First **pyridine-free** Hydranal reagents are launched
- 1998 Sigma-Aldrich Laborchemikalien introduced the first ethanol-based KF reagents, the **Hydranal E-types**
- 2008 Hydranal reagents brand change from Riedel-de Haën to **Fluka**
- 2009 Accreditation according to ISO 17025
- 2014 Accreditation according to ISO 17025 + ISO Guide 34
- 2015 Hydranal became part of **Honeywell** family



1980 changed the world of KF titration

Basic Forms of KF Titration

- **Volumetric titration:**

- with **one-** or **two-component reagents**
- water measured in: **mg**
- water content: 0.01% (100 ppm) – 100%

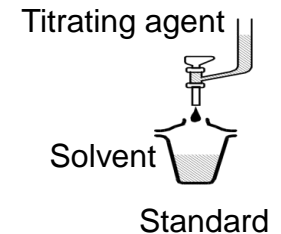

- **Coulometric titration:**

- with cell **with** or **without diaphragm**
- water measured in: **μg**
- water content: 0.001% (10 ppm) – ca. 5-10%

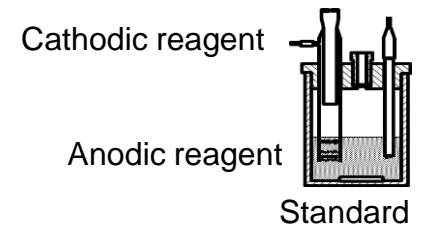

- **KF titration with an oven:**

- not a special titration technique
- indirect form of sample introduction
- used in combination with **volumetric** or **coulometric titration**

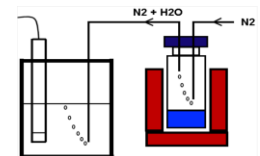

Consider sample properties for choosing the method, not just the water content!

HYDRANAL™

Karl Fischer Reagents



Karl Fischer Titration

Karl Fischer reaction mechanism:

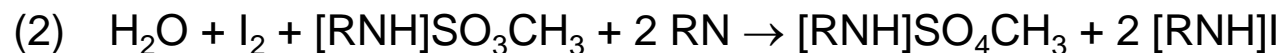
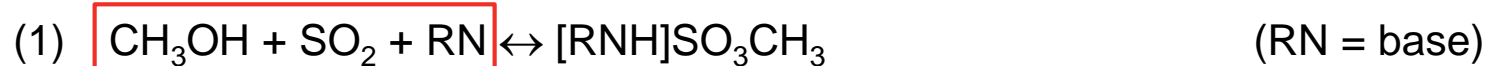

• Reagent for KF titration needs:

- iodine

- sulfur dioxide

- base

- solvent (alcohol)

→ provide intermediate product



- Base → speed, stability, buffering
- Solvent → reactivity, end-point indication, shelf life

KF reagent reacts quantitatively and selectively with water

Influence on pH Value

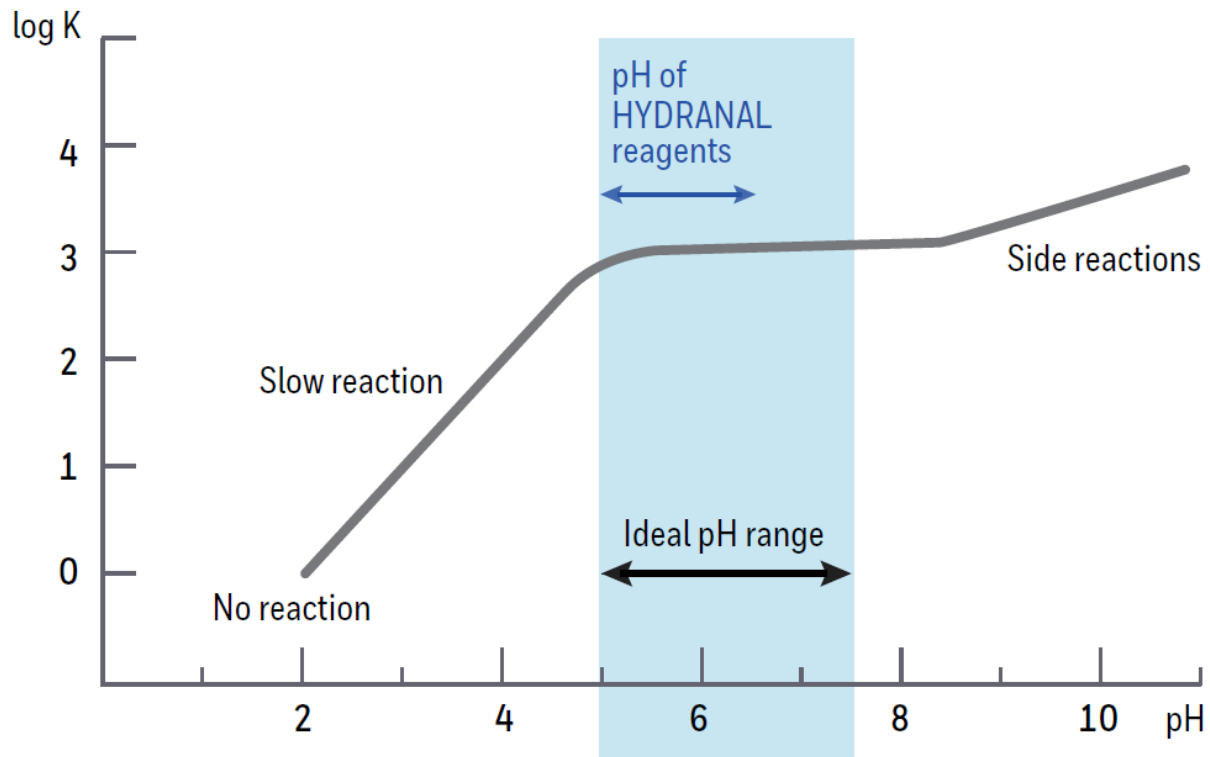

Titer of Reagent

$$\text{Titer (WE)} = \frac{\text{Weight of titrated water [mg]}}{\text{Consumption of reagent [mL]}}$$

- Example Titer **5.125**:
with **1.00 mL** consumed reagent, **5.125 mg** water have been titrated
- Product Specification:
 - HYDRANAL-Composite 5: titer 4.5-5.5 mg/mL (+/- 10%) → 5.35 mg/mL
 - HYDRANAL-Titrant 5: titer 4.95-5.05 mg/mL (+/- 1%)
 - HYDRANAL-Composite 2: titer 1.6-2.4 mg/mL (+/- 20%)
 - HYDRANAL-Titrant 2: titer 1.96-2.04 mg/mL (+/- 2%)
 - HYDRANAL-Composite 1: titer 0.8-1.2 mg/mL (+/- 20%)

WE = water equivalent

Titer of Reagent

- Influences on titer stability:
 - air humidity
 - temperature change (+1°C → titer change of -0.1%):
 - example: Titer 5.050 mg/mL
 - + 1°C (-0.1%) Titer 5.045 mg/mL
 - + 20°C (-2%) Titer 4.950 mg/mL

Volumetric KF Titration



	Two-component reagents	One-component reagents
Titrating agent	HYDRANAL-Titrant 2 (E) HYDRANAL-Titrant 5 (E) (contains iodine , alcohol)	HYDRANAL-Composite 1 HYDRANAL-Composite 2 HYDRANAL-Composite 5 (contains iodine , SO₂ , base , DEGEE)
Working medium	HYDRANAL-Solvent (E) (contains SO₂ , base , alcohol)	HYDRANAL-Methanol Dry HYDRANAL-Methanol Rapid HYDRANAL-CompoSolver E HYDRANAL K-type media or mixtures (contains alcohol)
pH	pH ≈ 6	pH ≈ 5
Advantages	<ul style="list-style-type: none"> ✓ high titration speed ✓ high accuracy (for low water content) ✓ high buffer capacity ✓ high titer stability 	<ul style="list-style-type: none"> ✓ unlimited water capacity ✓ widely used ✓ highly flexible (working medium)

DEGEE = Diethylene glycol monoethyl ether

Highest flexibility by using HYDRANAL-Composite one-component reagents

HYDRANAL-Composite

Improved quality:

- No crystal formation
- Better stability
- Same performance
- Formulation proprietary
- No methanol

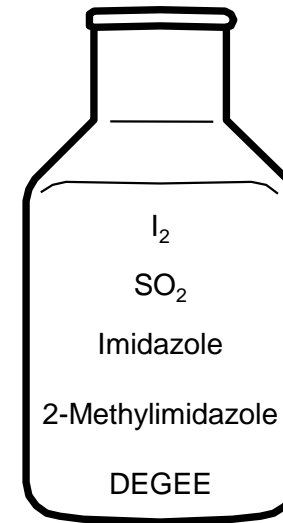

DEGEE = Diethylene glycol
monoethyl ether

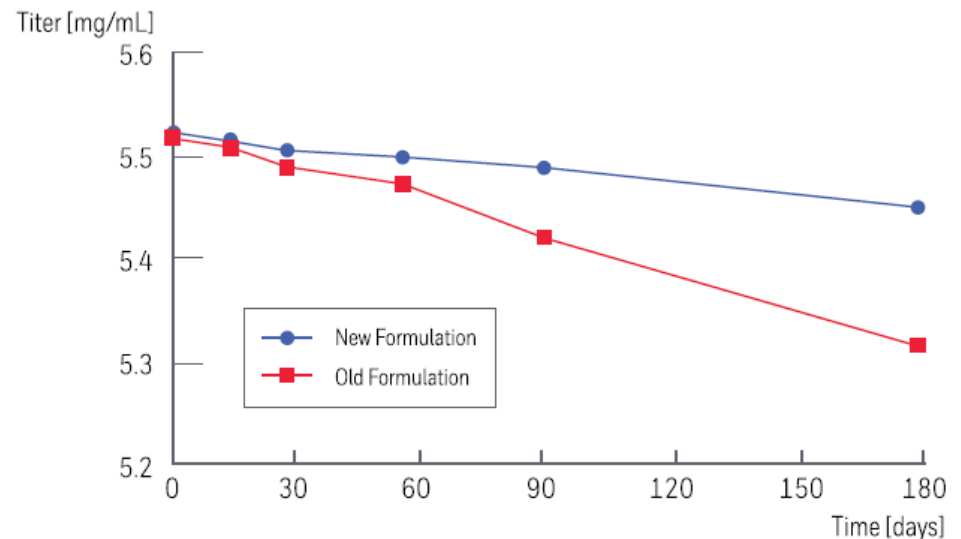

Speed of Volumetric KF Titration

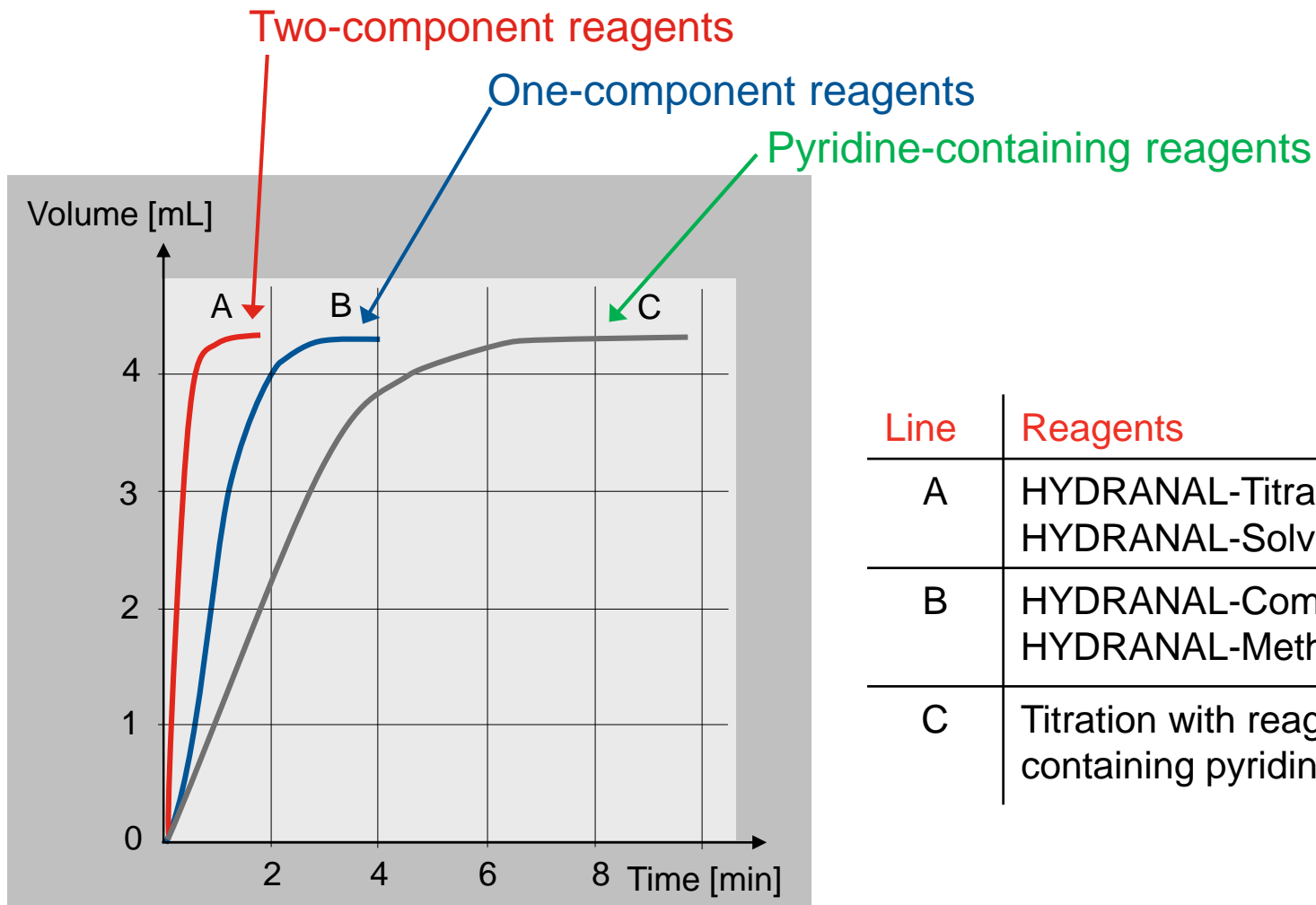

Line	Reagents
A	HYDRANAL-Titrant 5 + HYDRANAL-Solvent
B	HYDRANAL-Composite 5 + HYDRANAL-Methanol Dry
C	Titration with reagents containing pyridine

Titration of 40 mg of water

HYDRANAL-Methanol Rapid

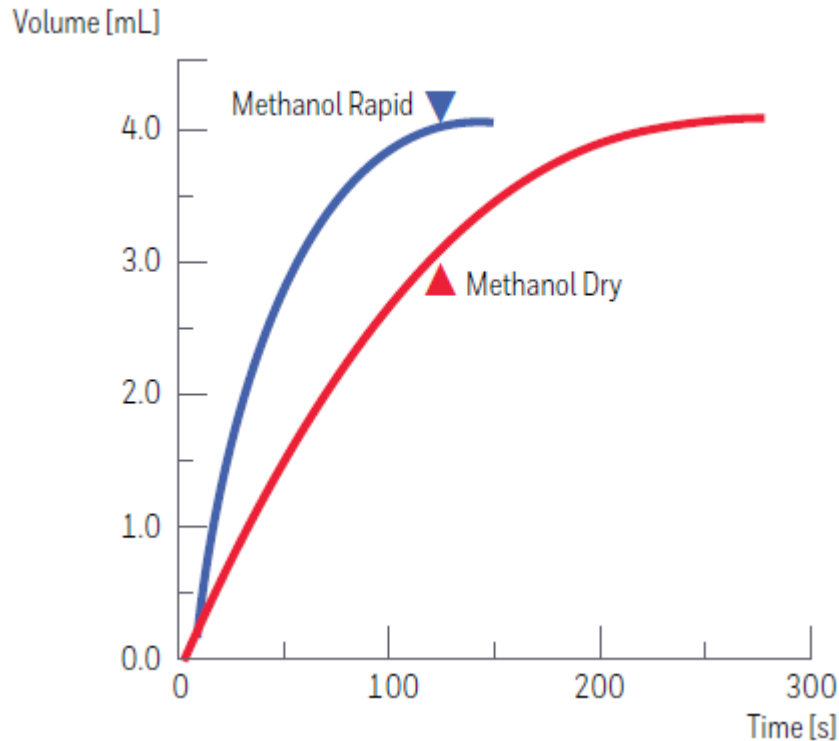

Titration of 20 mg of water

Advantages:

- Shorten titration time
- Higher accuracy
- Rapid end point

- HYDRANAL-Methanol Dry is not buffered (only methanol)
- HYDRANAL-Methanol Rapid contains accelerators (SO₂, imidazole)

Coulometric KF Titration

Karl Fischer reaction mechanism:

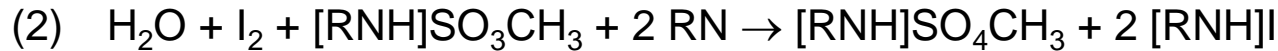

- Iodine electrochemically generated from the oxidation of iodide contained in the coulometric KF reagent
- Calculation based on the amount of produced (consumed) current over time (acc. to Faraday's law)
- Advantages of coulometric KF titration:
 - easy to use
 - for small amounts of water
 - high accuracy
 - completely glass cell

Iodine formation at the anode:

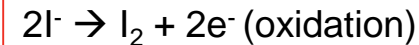

Hydrogen formation at the cathode:



Which Cell to Choose?

- Cell without diaphragm:

- more convenient for the user
- only one reagent required
- less cleaning

- Cell with diaphragm:

- if reagents contain solubilizer, like: chloroform, xylene, toluene, long chained alcohols
- reagent for ketones (free from methanol)
- in general, more accurate results for small amounts of water (low ppm-range)

Coulometric KF Titration

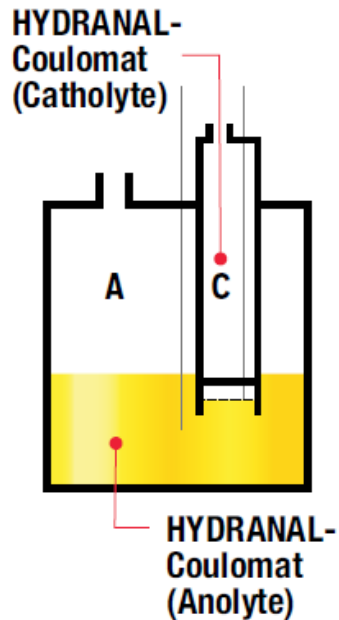

	Reagents preferred for cells with diaphragm	Reagents preferred for cells without diaphragm
Anolyte	HYDRANAL-Coulomat A* HYDRANAL-Coulomat Oil* HYDRANAL-Coulomat E HYDRANAL-Coulomat AG HYDRANAL-Coulomat AG-Oven HYDRANAL-Coulomat AG-H* HYDRANAL-Coulomat AK*	HYDRANAL-Coulomat AD HYDRANAL-Coulomat E HYDRANAL-Coulomat AG HYDRANAL-Coulomat AG-Oven
Catholyte	HYDRANAL-Coulomat CG HYDRANAL-Coulomat CG-K	Not used

* higher recovery when used with cell without diaphragm

HYDRANAL Reagents for Oils

Solvents for volumetric titration with one-component reagents

HYDRANAL-Solver (Crude) Oil (contains chloroform, xylene and methanol; fulfills the requirement of ASTM D 4377-00 for water determination in oils and solvents)

HYDRANAL-LipoSolver CM (contains chloroform and methanol)

HYDRANAL-LipoSolver MH (contains methanol and hexanol)

Solvents for volumetric titration with two-component reagents

HYDRANAL-Solvent CM (contains chloroform and methanol)

HYDRANAL-Solvent Oil (contains methanol and hexanol)

Analyte for coulometric titration with diaphragm

HYDRANAL-Coulomat Oil (contains chloroform, xylene & methanol)

Water standard

HYDRANAL-Water Standard Oil (based on mineral oil)

HYDRANAL-Water Standards



- For volumetric and coulometric KF titrations
- Manufactured according to current ISO standards
- Verified against NIST SRM 2890
- Long shelf life (up to 5 years)
- Convenient packaging
- Supplied with detailed instruction and Report of Analysis with exact water content
- **Liquid standards** are packaged in glass ampoules under argon. Each box contains ten single-use ampoules, easy to open (pre-notched).
- **Solid standards** are packed in amber glass bottles. They contain defined amounts of chemically combined water.



HYDRANAL-Water Standards

Type	Name	Form	Water content *
Analytical standards (tested against NIST SRM 2890)	HYDRANAL-Water Standard 10.0	Liquid	10.0 mg/g = 1.0%
	HYDRANAL-Water Standard 1.0	Liquid	1.0 mg/g = 0.1%
	HYDRANAL-Water Standard 0.1	Liquid	0.1 mg/g = 0.01%
	HYDRANAL-Water Standard 0.1 PC NEW!	Liquid	0.1 mg/g = 0.01%
	HYDRANAL-Water Standard Oil	Liquid	<50 ppm = 0.005%
	HYDRANAL-Standard Sodium Tartrate Dihydrate (34696)	Solid	~15.66%
	HYDRANAL-Water Standard KF Oven 140-160°C	Solid	~5.0%
	HYDRANAL-Water Standard KF Oven 220-230°C	Solid	~5.55%

* exact value on RoA

Report of Analysis		Honeywell Fluka	
Analysed for Honeywell Laborchemikalien GmbH, Supply chain, Wunstorfer Str.40, D-30926 Seelze			
Product: HYDRANAL®-Water Standard KF-Oven 140°C-160°C		Cat. No.: 34693	Lot: SZBG076AV
The water content of this lot is:		5.08 % ± 0.02 %	(k=2; 95% confidence interval)
The water content is analysed under ISO/IEC 17025 accreditation by direct volumetric KF-titration on 8 samples. The standard is traceable to high-purity water and tested against NIST SRM 2890.			
Honeywell Laborchemikalien GmbH Thomas Wendt, Supervisor Technical Service HYDRANAL® Wunstorfer Str.40, D-30926 Seelze	 	<i>Thomas Wendt</i>	QC release date Seelze 25. May 2016 Page 1 of 1 <small>REV.11</small>
Additional information (not under ISO/IEC 17025 accreditation): Expiration date: 18. Feb. 2021 Intended use: The water standard is intended to check KF oven equipment according to ISO 9001, chapter "Control of monitoring and measuring devices" in conjunction with a volumetric or coulometric KF titrator.			

HYDRANAL-Water Standard 0.1 PC **NEW!**

- Based on propylene carbonate
- Improved stability compared to HYDRANAL-Water Standard 0.1:
 - shelf life increased from 2 years to 3 years
 - can be stored at room temp. instead of 2-8°C

HYDRANAL-CRM Water Standards **NEW!**

- In 2014, Hydranal Technical Service in Seelze completed its combined accreditation according to **ISO/IEC 17025** and **ISO Guide 34**, the so-called “**Gold Standard Accreditation**”, which is the highest achievable quality level for producers of Certified Reference Materials (CRMs).
- With the double accreditation, Hydranal introduced the very first commercially available CRM Water Standards for Karl Fischer titration.

Type	Name	Form	Water content *
Certified Reference Materials	HYDRANAL-CRM Water Standard 10.0	Liquid	10.0 mg/g = 1.0%
	HYDRANAL-CRM Water Standard 1.0	Liquid	1.0 mg/g = 0.1%
	HYDRANAL-CRM Sodium Tartrate Dihydrate	Solid	~15.66%

* exact value on CoA

Sample Preparation: Sample Handling



Sample size calculations

$$\text{Sample size [g]} = 0.5 \times \frac{\text{Burette's volume [mL]} \times \text{Titer [mg/mL]}}{\text{Expected water content [mg/g]}}$$

Sample	Sample size	Titrant volume used
100% water = 1000 mg/g	Titer 5: 25-50 mg Titer 2: 10-20 mg	5-10 mL 5-10 mL
15.6% water = 156 mg/g (34696 HYDRANAL-Sodium Tartrate Dihydrate)	Titer 5: 150-200 mg Titer 2: ca. 80 mg	4.7-6.2 mL 6.2 mL
1.0% water = 10 mg/g (34849 HYDRANAL-Water Standard 10.0)	Titer 5: ca. 2 g Titer 2: 1-2 g	4 mL 5-10 mL

**Titrant volume used should not exceed burette volume!
Ideally: half of burette volume.**

Sample Size Recommendations

		Titer 5 mg/mL			Titer 2 mg/mL			Titer 1 mg/mL		
		Burette volume			Burette volume			Burette volume		
		5 mL	10 mL	20 mL	5 mL	10 mL	20 mL	5 mL	10 mL	20 mL
		Recommended sample size (g)			Recommended sample size (g)			Recommended sample size (g)		
Expected water content	90 %	X	0.04	0.08	0.007	0.015	X	X	X	X
	75 %	X	0.05	0.1	0.01	0.02	X	X	X	0.02
	50 %	X	0.08	0.16	0.015	0.03	0.05	X	0.015	0.025
	20 %	0.08	0.125	0.25	0.025	0.05	0.1	X	0.025	0.05
	10 %	0.125	0.25	0.5	0.05	0.1	0.2	0.025	0.05	0.1
	5 %	0.25	0.5	1	0.1	0.2	0.4	0.05	0.1	0.2
	2.5 %	0.5	1	2	0.2	0.4	0.8	0.1	0.2	0.4
	0.25 %	5	10	20	2	4	8	1	2	4
	0.1 % (1000 ppm)	12.5	25	25	5	10	20	3	6	12
	0.01 % (100 ppm)	25	25	X	25	25	X	25	25	X
	0.001 % (10 ppm)	X	X	X	25	X	X	25	X	X

Consumption >1/2 burette volume

Consumption approx. 1/2 burette volume

Consumption < 1/2 burette volume

X = not recommended

Liquid and Solid Samples Handling



Every sample should be weighed by difference!

Liquid Water Standards Handling

- Standards in **8 mL ampoules** → use **10 mL glass syringe**
 - HYDRANAL-CRM Water Standard 10.0
 - HYDRANAL-Water Standard 10.0
 - HYDRANAL-Water Standard Oil
- Standards in **4 mL ampoules** → use **5 mL glass syringe**
 - HYDRANAL-CRM Water Standard 1.0
 - HYDRANAL-Water Standard 1.0
 - HYDRANAL-Water Standard 0.1
 - HYDRANAL-Water Standard 0.1 PC
- Rinse the syringe with 1 mL of water standard and draw the rest of the standard into the syringe in order to protect it against air influences.
- The amount of one ampoule is dedicated for rinsing the syringe followed by a triple determination of the water content.

Troubleshooting: Sample Dissolution



Solutions for Solubility Problems

Matrix	Variation of titration
Fats, oils, long-chained hydrocarbons	Addition of long-chained alcohols, chloroform or xylene
Proteins, carbohydrates	Addition of formamide
Other insoluble substances	<ul style="list-style-type: none">• Titration at 50°C or in boiling methanol• Homogenizing device• Extraction of water with suitable solvent• KF oven method

Sample Dissolution in Volumetric Reagents

Solubilizer	Sample	Amount	Ratio to methanol
1-Hexanol (long-chained alcohols)	for long chained hydrocarbons, dispersion of oils	max. 50%	(1:1)
Chloroform	for oils, organic samples	max. 70%	(2:1)
Xylene, Toluene	for crude oil, organic samples	max. 70%	(2:1)
Formamide (fresh solution, max. 2 days)	for solids, sugars, proteins	max. 50%	(1:1)

DMSO (dimethyl sulfoxide) – not recommended, alters the KF reaction, results are too low

HYDRANAL Auxiliary Reagents

For dissolution

HYDRANAL-Formamide dry (max. 0.02% H₂O)

HYDRANAL-Chloroform (max. 0.01% H₂O)

HYDRANAL-Xylene (max. 0.01% H₂O)

Sample Dissolution in Coulometric Reagents

- Coulometric reagents with solubilizing agents (based on methanol):
 - HYDRANAL-Coulomat A (contains chloroform)
 - HYDRANAL-Coulomat Oil (contains xylene and chloroform)
 - HYDRANAL-Coulomat AG-H (contains long-chained alcohols)
- Formamide only limited
 - cell without diaphragm
 - external sample treatment
 - no mixture of reagent and formamide

Titration at Elevated Temperature

- **Titration at 40-50°C:**
double-walled titration cell
(connected to water bath)
- **Titration in boiling methanol:**
for volumetric one-component reagents
with reflux condenser and heating mantle
(custom-made titration cell required)

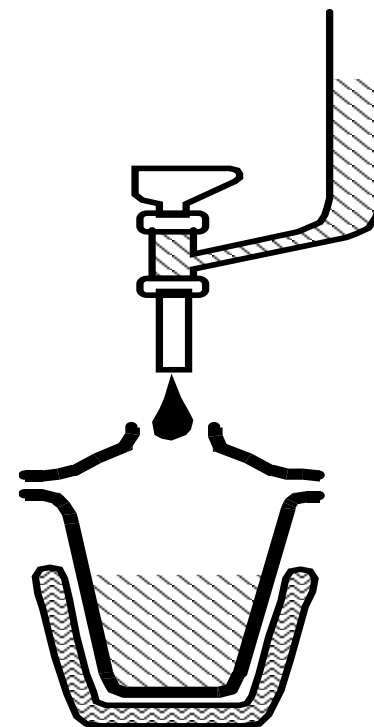

Homogenizing Device

- High speed stirrer
- Homogenizes the sample
- Better dissolution and extraction
- Shortens analysis time
- Use in addition to solubilizers and heat



Troubleshooting: Water Extraction



Internal Water Extraction (Sample Dissolution)

Solubilizer	Sample
1-Hexanol (long-chained alcohols)	for long chained hydrocarbons, dispersion of oils
Chloroform	for oils, organic samples
Xylene, Toluene	for crude oil, organic samples
Formamide	for solids, sugars, proteins

External Water Extraction

- Samples releasing water very slowly
- Very inhomogeneous samples – large sample masses required
- Procedure:
 - general rule: 1 mL of dry methanol will extract approx. 1 mg of water
 - calculate volume of dry solvent needed
 - weigh the sample
 - weigh the solvent added
 - prepare **blank** as above
 - stir for few hours
 - take an aliquot and titrate



Karl Fischer Oven

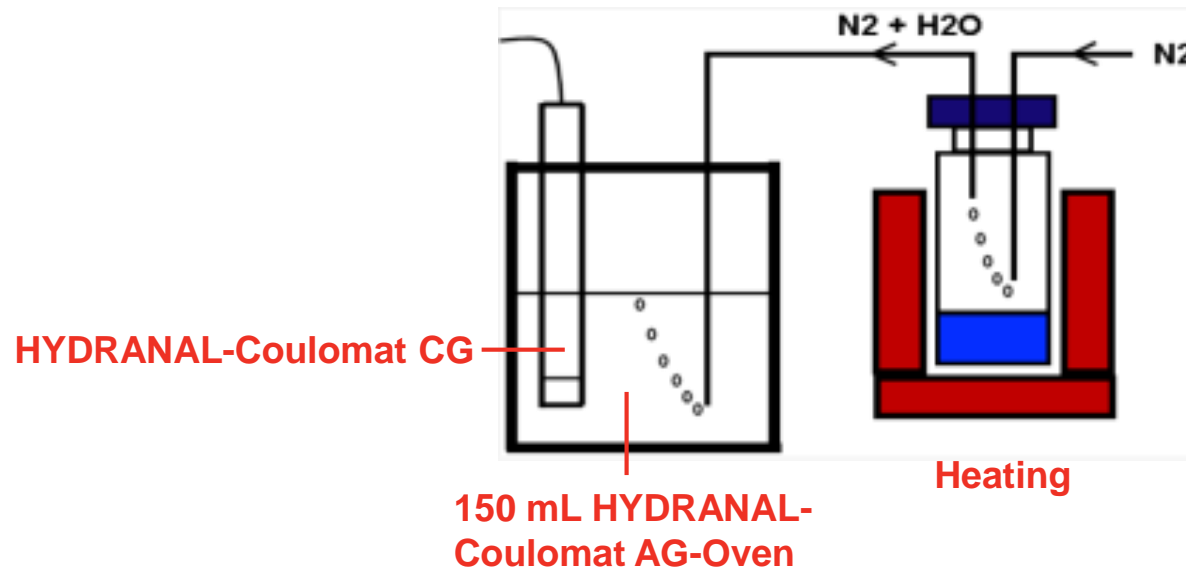

Karl Fischer Oven

- Ideal **reagent** is 34739 HYDRANAL-Coulomat AG-Oven with especially low drift:
 - methanol evaporates from the titration cell through the carrier gas
 - in Coulomat AG-Oven methanol is partially substituted with propylene glycol for better stability of drift and overall performance
 - at the end of a working day the original level shall be refilled by addition of dry methanol
- **Carrier gas** (**dried** by passing through molecular sieves):
 - air
 - nitrogen, argon – for samples sensitive to oxygen
- Ideal **heating temperature** for the sample:
 - sample water should be released as fast as possible, but decomposition of the sample must be avoided

Temperature Ramp for KF Oven

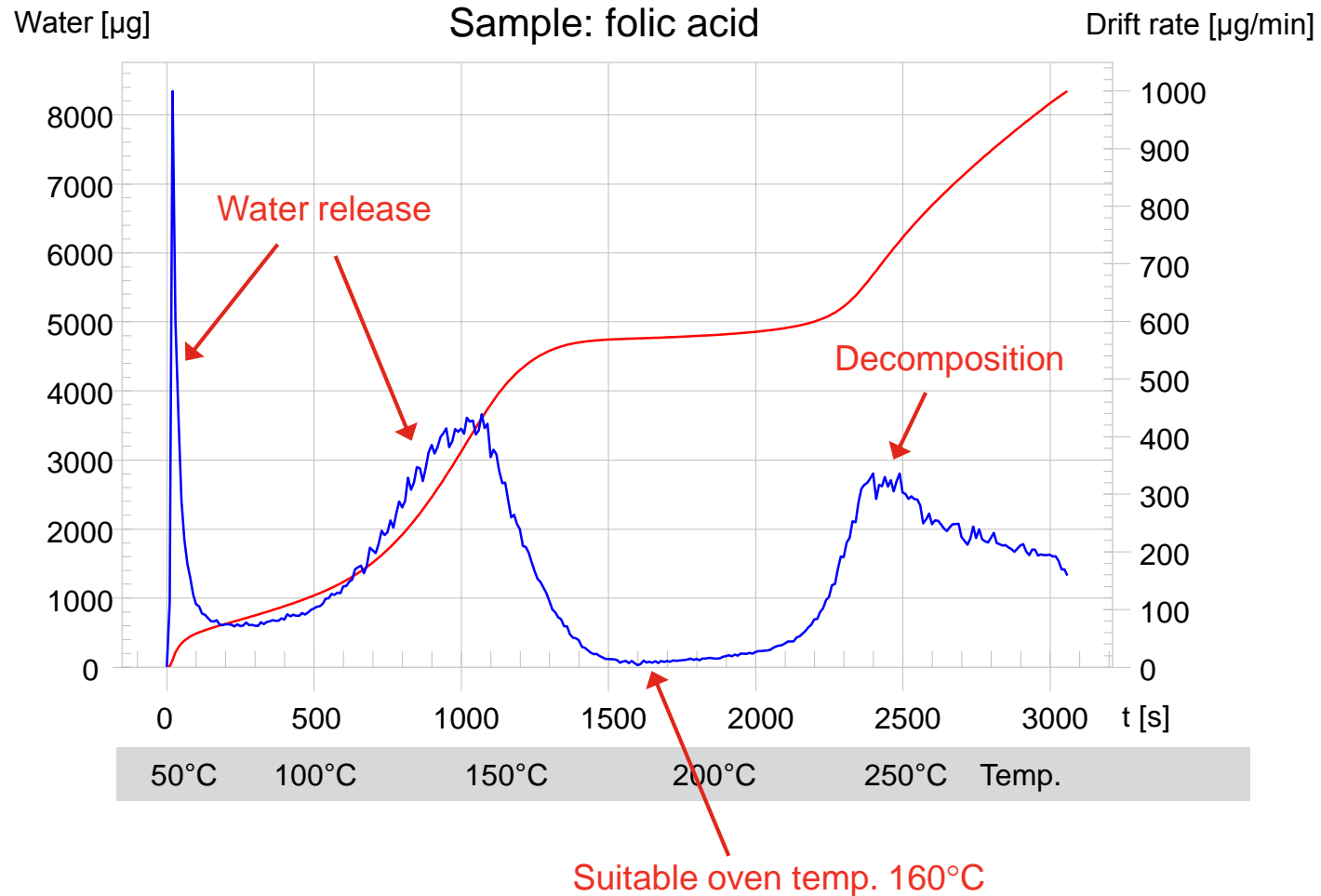

KF Oven Temperature

Sample	Oven temperature
Biodiesel	100°C
Oils containing additives	80-140°C
Folic acid	160°C
Polypropylene	160-180°C
Polycarbonate	180°C
Polyamide 66	200°C
Zinc peroxide	200°C
Calciumsulfate dihydrate	300°C
tri-Magnesium phosphate	300°C

Troubleshooting: Side Reactions



Side Reactions with Ketones and Aldehydes

- Aldehydes and ketones react with methanol to form acetals and ketals respectively – reaction forms water, which is also titrated, resulting in vanishing end points and incorrectly high water content

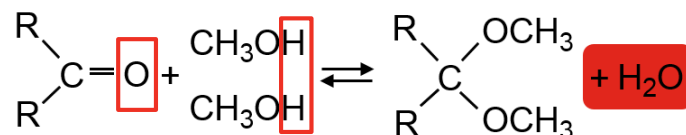

- Additionally, aldehydes can cause a second side reaction, the bisulfite addition, which consumes water and leads to incorrectly low water content



HYDRANAL-K Type Volumetric Reagents

- Specially designed for water determination in aldehydes and ketones without side reactions

Volumetric titrating agents	Volumetric working media
HYDRANAL-Composite 5 HYDRANAL-Composite 5 K	HYDRANAL-Medium K HYDRANAL-KetoSolver HYDRANAL-Working Medium K

- HYDRANAL-Composite 5 can be used with ketones (no methanol)
- HYDRANAL-Composite 5 K is less reactive than Composite 5, can prevent bisulfite addition to a large extent, so should be used with aldehydes (also useful for some ketones)
- HYDRANAL-Medium K is less toxic working medium – should be the first choice.

Influence of Working Media for Ketones

Titration of 5 mL acetone with HYDRANAL-Composite 5 in different working media

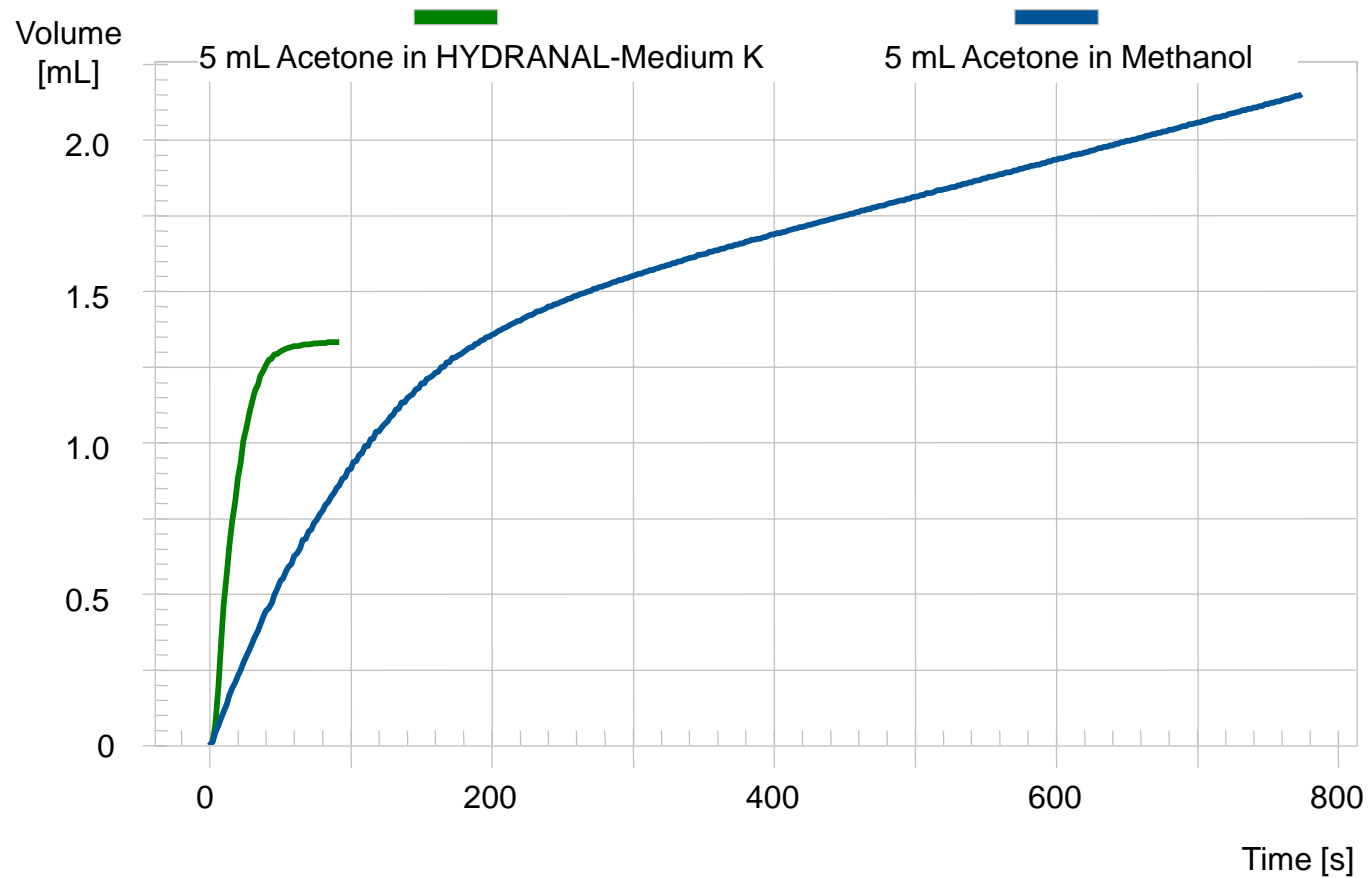

HYDRANAL-K Type Coulometric Reagents

- Coulometric titration should be used for ketone samples only, it is not advised for reactive aldehydes
- Only cells with diaphragm should be used

**Coulometric reagent –
anolyte**

HYDRANAL-Coulomat AK

**Coulometric reagent –
catholyte**

HYDRANAL-Coulomat CG-K

Titration at Low Temperature

- Method to suppress slow side reactions
- Titration vessel placed in an ice bath or double-walled titration cell connected to cooling bath
- Recommended only for volumetric titration:
 - HYDRANAL-Solvent/Titrant: max. -60°C
 - HYDRANAL-Composite: max. -20°C
(due to increasing viscosity)

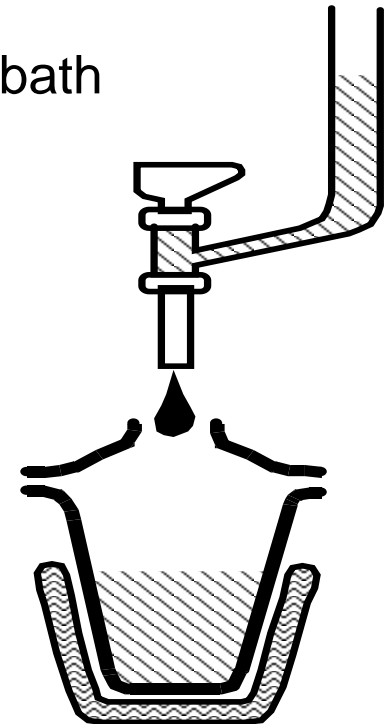

Troubleshooting: Neutralization



Neutralization of Acids and Bases

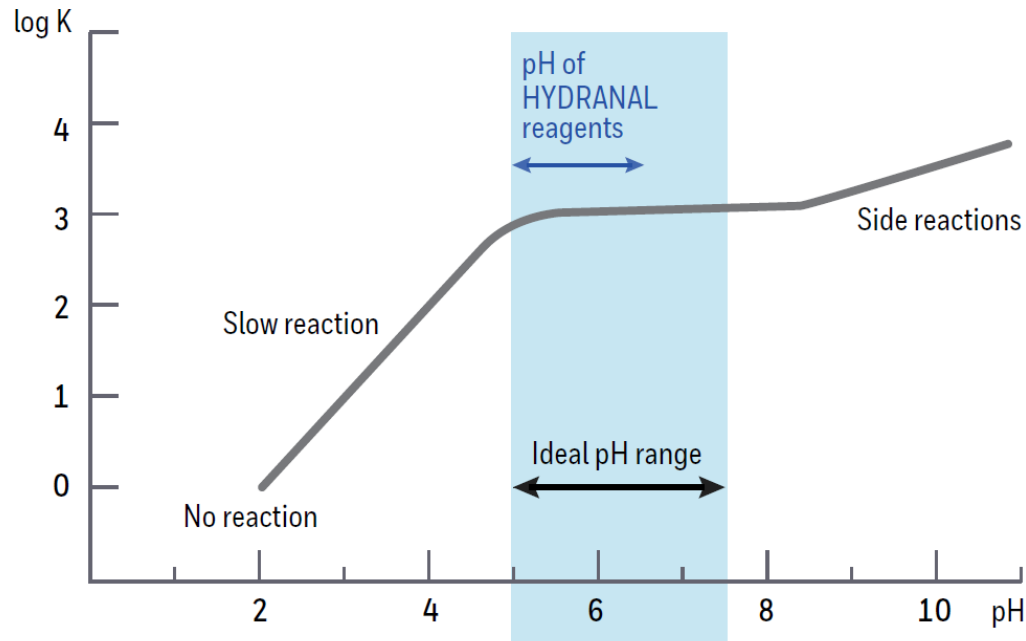

- Checking the pH value:
 - alcoholic medium → only rough check of pH value
 - use pH electrode or pH paper (add deionised water)

HYDRANAL Auxiliary Reagents

For neutralization

HYDRANAL-Buffer Acid (buffer capacity 5 mmol acid / mL)

HYDRANAL-Buffer Base (buffer capacity 1 mmol base / mL)

HYDRANAL-Imidazole (max. 0.1% H₂O)

HYDRANAL-Benzoic acid (max. 0.2% H₂O)

HYDRANAL-Salicylic acid (max. 0.2% H₂O)

Neutralization of Acids and Bases: Modifications of Working Media

One-component volumetric titration	Two-component volumetric titration	Coulometric titration (cell with diaphragm)
Neutralization of acids		
Add (1:2) HYDRANAL-Buffer Acid or use alone	Add HYDRANAL-Imidazole (7 g/30 mL) or use HYDRANAL-Buffer Acid	Add HYDRANAL-Imidazole (20 g/100 mL)
Neutralization of bases		
Add HYDRANAL-Benzoic Acid or HYDRANAL-Salicylic Acid (5-7 g/30 mL) or use HYDRANAL-Buffer Base	Add HYDRANAL-Benzoic Acid or HYDRANAL-Salicylic Acid (5-7 g/30 mL)	Add HYDRANAL-Benzoic Acid (20 g/100 mL)

Note: Use of imidazole with pure methanol in one-component volumetric titration is not recommended (shifts pH too far).

Tips & Tricks: Drift Minimizing



Humidity of Air

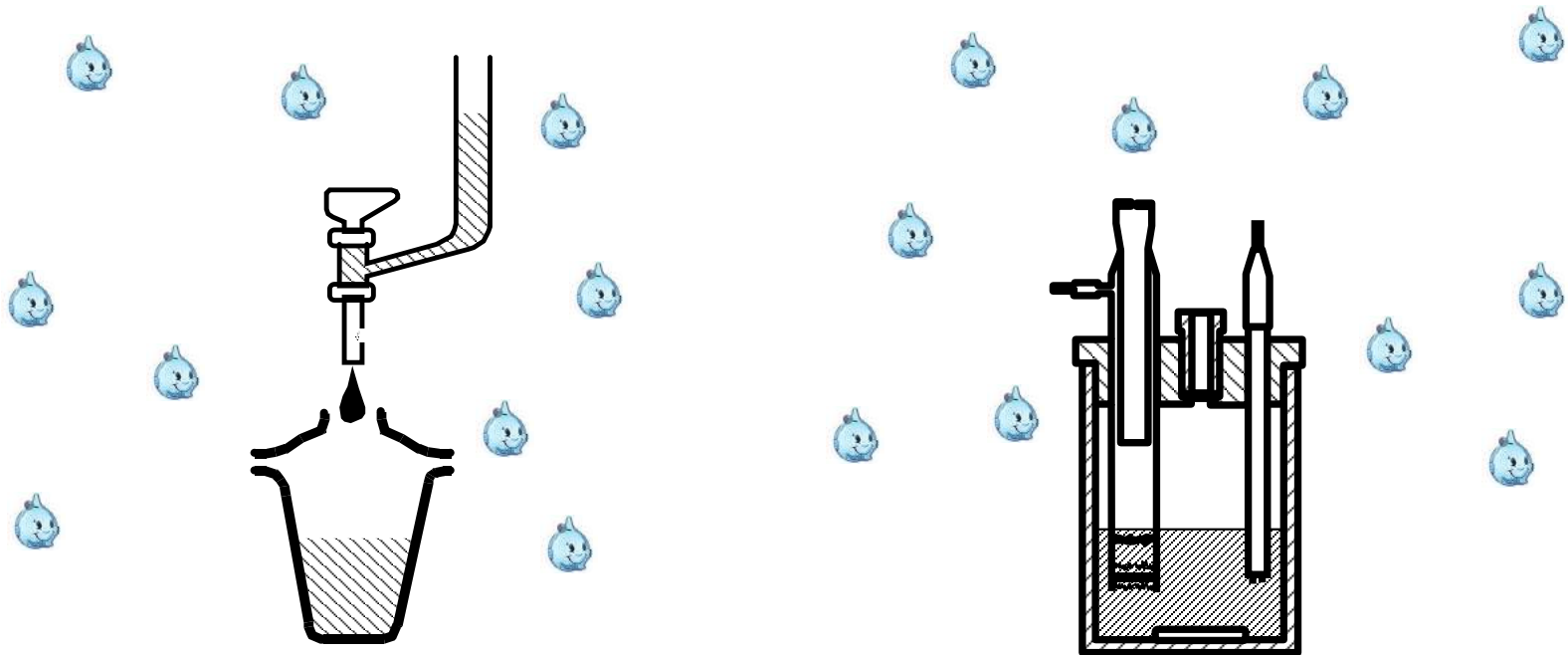

At 20°C and a relative air humidity of 60%, 1 L of air contains 12 mg of water

Drying Agents for KF Titration

- Every reagent bottle and every titration vessel needs a drying tube (also important for improving titer stability)
- **HYDRANAL-Humidity Absorber**
 - beads, with indicator, water absorption capacity < 25%
 - amorphous alumina silica gel
 - color change from orange to almost colorless
 - regeneration at 140°C (until color comes back)
- **HYDRANAL-Molecular Sieve 0.3 nm**
 - beads, without indicator, water absorption capacity > 15%
 - regeneration at max. 300°C, min. 4 h



Drift in the Volumetric Cell

- Definition of drift: **volume of reagent (iodine) permanently consumed**
 - humidity from ambient air penetrates into the cell
 - in volume / time [$\mu\text{L}/\text{min}$] or water amount / time [$\mu\text{g}/\text{min}$]
- Recommended acceptable maximum drift (start of titration): **10 $\mu\text{L}/\text{min}$**
- End-point criterium: drift < 20 $\mu\text{L}/\text{min}$
- Drift calculations:
 - 10 $\mu\text{L}/\text{min}$** = 0.01 mL reagent titer 5 → 50 μg water / min
 - 10 $\mu\text{L}/\text{min}$** = 0.01 mL reagent titer 2 → 20 μg water / min
 - 10 $\mu\text{L}/\text{min}$** = 0.01 mL reagent titer 1 → 10 μg water / min
- Accepted drift means accepted amount of water migrating into the titration vessel – the cell is stable for using with that titrant
- Cell with reagent titer 1 needs perfect conditions of titration vessel
- New user should always start with reagent titer 5

Drift in the Coulometric Cell

- After fresh refill with HYDRANAL-Coulomat:
 - after short time (15 min): $< 10 \mu\text{g}/\text{min}$
 - ideally: $< 5 \mu\text{g}/\text{min}$
 - often: $< 2 \mu\text{g}/\text{min}$
- After longer use of reagent:
 - max. $20 \mu\text{g}/\text{min}$ (e.g. when determining ketones)
- Unsteady, high drift value → change of reagent necessary

Coulometric Cell - Analyte

- Anodic compartment is filled with approx. 100 mL analyte reagent
- Change reagent when:
 - maximum sample volume is reached (cell is full!) = 100 mL reagent plus max. 50 mL sample
 - unsteady or increasing drift
 - water capacity limit is reached: 100 mL analyte has a capacity of 1'000 mg water (= 1'000'000 µg)
- The same rules for cell without diaphragm

Coulometric Cell - Catholyte

- Moisture in the cathodic compartment will not be eliminated (no KF reaction in the cathodic compartment!)
- Catholyte used for > 1 week:
 - formation of lower sulfur compounds
 - reaction with iodine, diffusion through diaphragm, oxidation at the anode
 - high drift and contaminated diaphragm
- After several weeks:
 - cathode turns black and cathodic compartment starts to smell
 - precipitations / crystal formation may occur

Drift with KF Oven

- Low and stable drift needed
- Drift is subtracted automatically for the duration of determination
- **Constant flow rate of the dried carrier gas** (air, nitrogen, argon)
 - 120-150 mL/min for tube furnaces
 - 70-80 mL/min for vial oven
- **Ideal reagent:**
 - HYDRANAL-Coulomat AG-Oven with especially low drift
- **Ideal heating temperature:**
 - to release the water quickly, but without decomposition of the sample

Tips & Tricks: Safer Reagents



New Classification According to GHS

- New and more stringent evaluation of chemicals by the European Chemicals Agency (ECHA) – imidazole classified as a dangerous component
- New guidelines defining how to safely handle HYDRANAL products
- According to the new European Regulation on Classification, Labeling and Packaging of chemical substances and mixtures (CLP):
 - reagents containing imidazole of 0.3% w/w or more must show the following Pictograms and Hazard statements:
 - GHS08 (Health Hazard)
 - H360D (May damage the unborn child)



New Classification According to GHS

- Newly measured values for imidazole concern **oral intake** of the substance, whereas values for dermal and inhalation remain unchanged
- Karl Fischer reagents are handled in **closed systems**
 - **direct contact** with the chemicals is typically **prevented** and can only occur accidentally
- Hydranal reagents contain **imidazole only in dissolved and diluted form**
- Imidazole in its **free form** is only contained to a low degree
 - risk of exposure **to inhalation of powder dust is negligible**
 - use of **personal protection is advised**, especially gloves (avoid skin contact)
 - an oral intake is quite unlikely

HYDRANAL-E Type Reagents

- Based on ethanol instead of methanol – less dangerous for user and environment
- Improve solubility of long-chained hydrocarbons especially in HYDRANAL-CompoSolver E
- Ketones like acetone can be titrated in HYDRANAL-CompoSolver E (not possible in methanol-based working media)
- Corresponding to regulations of ISO 14001 (environmental management)

Green HYDRANAL Reagents Based on Ethanol / DEGEE

One-component volumetric reagents	Two-component volumetric reagents	Coulometric reagent
HYDRANAL-Composite 1 HYDRANAL-Composite 2 HYDRANAL-Composite 5 HYDRANAL-Composite 5 K HYDRANAL-CompoSolver E	HYDRANAL-Titrant 2 E HYDRANAL-Titrant 5 E HYDRANAL-Solvent E*	HYDRANAL-Coulomat E

* should be used quickly after opening

Applications: Pharmaceutical Industry



Pharmacopeia Suitability Test

2.5.12. Semi-Microdetermination (Volumetric titration)

Method A

„Introduce into the titration vessel *methanol R*, or the solvent indicated in the monograph or recommended by the supplier of the titrant. Where applicable for the apparatus used, eliminate residual water from the measurement cell or carry out a pre-titration. Introduce the substance to be examined rapidly and carry out the titration, stirring for the necessary extraction time.”

Method B

Back titration (basically same requirements)

Suitability

„The accuracy of the determination with the chosen titrant must be verified for each substance to be examined. [...] **The water content of the substance to be examined is determined using the reagent/solvent system. Thereafter, sequential known amounts of *water R* are added in an appropriate form (at least 5 additions) and the cumulative water content determined after each addition.**“

Problems with Ph.Eur. Protocols

Sample	Ph. Eur.	Troubleshooting
Calcium acetate	+ 2 mL Acetic acid	5 g Salicylic acid
D(-) Fructose	Methanol	+ 10 mL Formamide
D(+) Glucose	Methanol	+ 10 mL Formamide
Gentamicin sulfate	Methanol	+ 10 mL Formamide
Ethyl acetate	Titer 5	Titer 2
DMSO	Recovery rate 75%	no solution

Suitability tests are available on request (hydranal@honeywell.com)

Suitability Test Protocol Example

Suitability test according to Ph.Eur., method 2.5.12 Water semi-micro determination

Water determination by Karl Fischer titration using HYDRANAL®- Composite

Product Gentamicin sulphate

Titrant HYDRANAL®-Composite 5 **Titer** 5.272 mg/mL
Working medium 30 ml HYDRANAL®-Methanol dry

Sample handling Procedure By means of a powder funnel. Weigh by difference.
 The working medium is placed in the titration vessel and titrated to dryness with the titrant.

Then the sample is added and titrated in the same way to a stable end point.
Recovery of water added After achieving the end point, sequential known amounts of water are added and titrated in the same way.

	Sample	Water added				
		1	2	3	4	5
Sample size (g)	0.2857					
Water added (mg)		27.77	28.67	27.85	27.83	27.85
Water found (mg)	26.8486	32.13	28.46	27.85	27.88	27.91
Water content (%)	9.3971					
Recovery (%)		115.71	99.28	100.03	100.16	100.22

The reagent/solvent system is considered to be acceptable if:

- The mean recovery is between 97.5% and 102.5%
- The slope b is between 0.975 and 1.025 (deviation +/- 2.5 %).
- The error e1 and e2 are not greater than 2.5%

mean recovery (%) 103.08
 slope 1.000
 error 1 (%) 15.92
 error 2 (%) 15.97

Test results do not fulfil the requirements according to Ph.Eur.

Since the sample does not dissolve sufficiently in pure methanol, found water content is too low and recovery of added water is too high.

A suitability test for the use of a mixture of methanol and formamide as working medium is available on request.

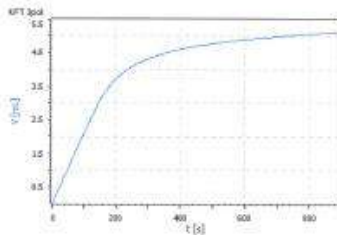

Seitzer, 12.07.07 1604 pm

Suitability test according to Ph.Eur., method 2.5.12 Water semi-micro determination

Water determination by Karl Fischer titration using HYDRANAL®- Composite

Product Gentamicin sulphate

Titrant HYDRANAL®-Composite 5 **Titer** 5.272 mg/mL
Working medium 20 ml HYDRANAL®-Methanol dry + 20 ml HYDRANAL®-Formamide dry

Sample handling Procedure By means of a powder funnel. Weigh by difference.
 The working medium is placed in the titration vessel and titrated to dryness with the titrant.

Then the sample is added and titrated in the same way to a stable end point.
Recovery of water added After achieving the end point, sequential known amounts of water are added and titrated in the same way.

	Sample	Water added				
		1	2	3	4	5
Sample size (g)	0.3383					
Water added (mg)		38.55	39.00	38.56	39.11	21.18
Water found (mg)	38.6723	38.36	38.78	38.22	38.62	20.90
Water content (%)	11.5004					
Recovery (%)		99.49	99.43	99.11	98.74	98.79

The reagent/solvent system is considered to be acceptable if:

- The mean recovery is between 97.5% and 102.5%
- The slope b is between 0.975 and 1.025 (deviation +/- 2.5 %).
- The error e1 and e2 are not greater than 2.5%

mean recovery (%) 99.11
 slope 0.990
 error 1 (%) 0.69
 error 2 (%) 1.68

Test results fulfil the requirements according to Ph.Eur.

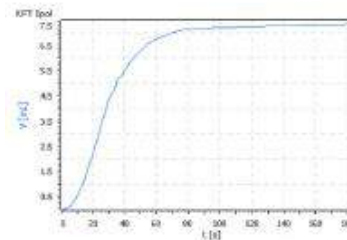

Seitzer, 12.07.07 1604 pm

Application example: Aspartic acid (L 010)

- At room temperature, the inherent moisture of the magnesium salt of aspartic acid and the moisture in the magnesium salt of aspartic acid hydrochloride is released so slowly that only a titration at **50°C** is possible.
- The magnesium salt of aspartic acid also requires the presence of **formamide** as solvent agent. Formamide also improves the solubility of the magnesium salt of aspartic acid hydrochloride.
- **Procedure:**
 - Two-component volumetric titration at 50°C
 - Sample size:
approx. 0.3 g aspartic acid magnesium salt or
0.15 g aspartic acid magnesium salt hydrochloride

**25 mL HYDRANAL-Solvent +
10 mL HYDRANAL-Formamide dry**

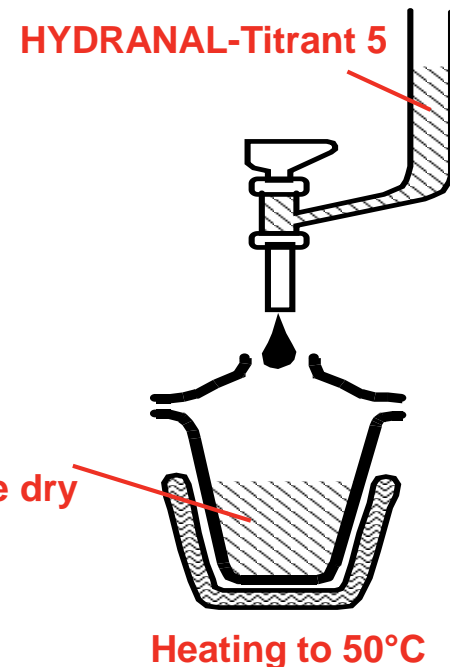

Application example: Magrocol 8000 (L 633)

- This sample does not dissolve easily in the alcohol-based KF media. To ensure that it dissolves completely, it is recommended that **xylene** is added.
- **Procedure:**
 - One- or two-component volumetric titration
 - Sample size: 2 g

HYDRANAL-Composite 5

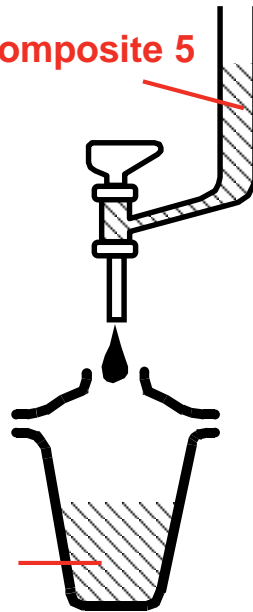

20 mL HYDRANAL-
Methanol dry/Rapid +
20 mL HYDRANAL-Xylene

HYDRANAL-Titrant 5

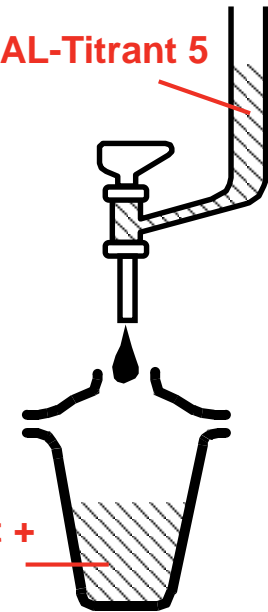

20 mL HYDRANAL-Solvent +
20 mL HYDRANAL-Xylene

Application example: Multivitamin (L 404)

- Tablets and powder
- Problems:
 - solubility in methanol (addition of formamide and heating to 50°C didn't give reproducible results)
 - side reaction with iodine
- **Procedure:**
 - Coulometric titration with **KF oven**
 - Sample size: 35 mg

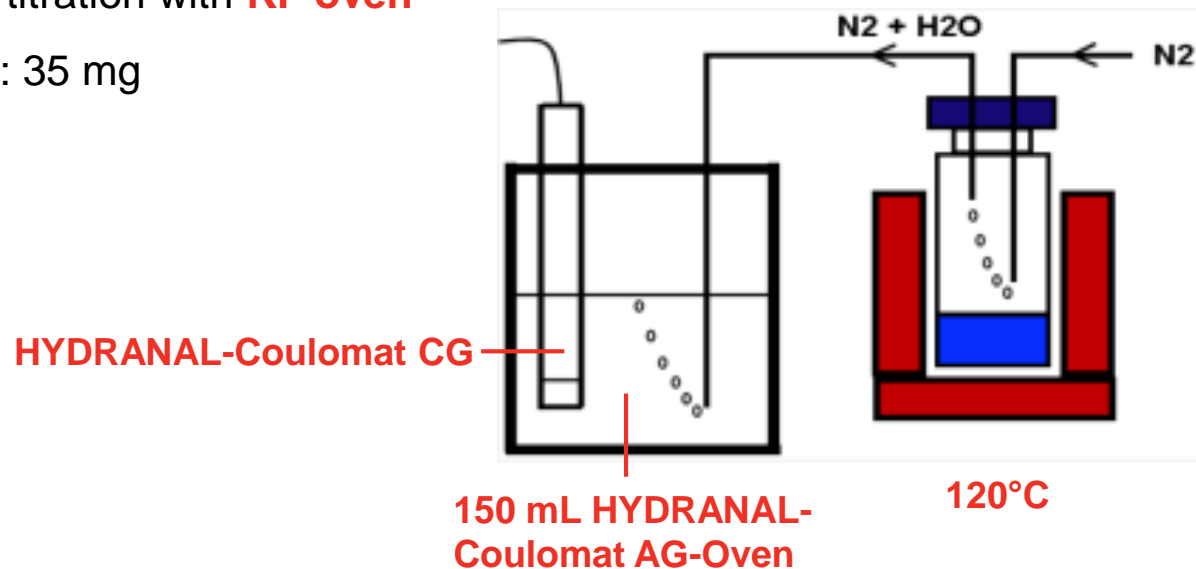

Application example: Vitamin B12 (L 711)

- Problems:
 - hygroscopicity (weight increase: 1% after 30 s, 7% after 2 h in the air)
 - solubility (time to dissolve **150 mg sample**: 3 min./Methanol dry, 1.5 min./Methanol Rapid and 1 min./Solvent)
- **Procedure:**

	One-component volumetric titration	Two-component volumetric titration	Coulometric titration with KF oven
Titrating agent	Hydranal-Composite 5 or 2	Hydranal-Titrant 5 or 2	-
Working medium	30 mL Hydranal-Methanol Dry or Rapid	30 mL Hydranal-Solvent	150 mL Hydranal-Coulomat AG-Oven (anolyte)
Sample size	0.15 g	0.15 g	0.05 g
Temperature	RT	RT	140°C

Application example: Toothpaste (L 029)

- Toothpaste releases its water content so slowly that a determination is not possible at RT. At 50°C titration still takes ca. 30 min, with added **formamide** - about 15 min.
- With a **homogenizer** the sample is dispersed within few seconds, titration time is only 1.5 min (in methanol).
- Direct titration only if the toothpaste does not contain any carbonates (they might react in the acidic KF medium producing water).
- **Procedure:**
 - Volumetric titration (high water content: ~40%)
 - Sample size: 60-100 mg
 - The toothpaste has to be homogenized before the sample is taken
 - Sample handling: 1 mL syringe without needle

Application example: Toothpaste (L 029)

	One-component volumetric titration		Two-component volumetric titration		Volumetric titration with KF oven
	with homogenizer	without homogenizer	with homogenizer	without homogenizer	
Titrating agent	Hydranal-Composite 5	Hydranal-Composite 5	Hydranal-Titrant 5	Hydranal-Titrant 5	Hydranal-Composite 5
Working medium	40 mL Hydranal-Methanol Dry or Rapid	20 mL Hydranal-Methanol Dry or Rapid + 10 mL Hydranal-Formamide dry	40 mL Hydranal-Solvent	20 mL Hydranal-Solvent + 10 mL Hydranal-Formamide dry	40 mL Hydranal-Methanol Dry
Homogenizer speed	5,000 r/min	-	5,000 r/min	-	-
Temperature	RT	RT	RT	RT	140°C

Applications: Petrochemical Industry



Application example: Crude Oil (L 108, L 148)

- Intensive **homogenisation** of samples is a needed for reproducible results.
- Crude oil requires: **chloroform** to dissolve the oil and **xylene** to dissolve the tar components. If the tar is not finely dispersed, it can coat the electrode which leads to indication problems.
- **Procedure:**
 - One-component volumetric or coulometric titration
 - Sample size: 4 g for volumetry, 1-2 g for coulometry

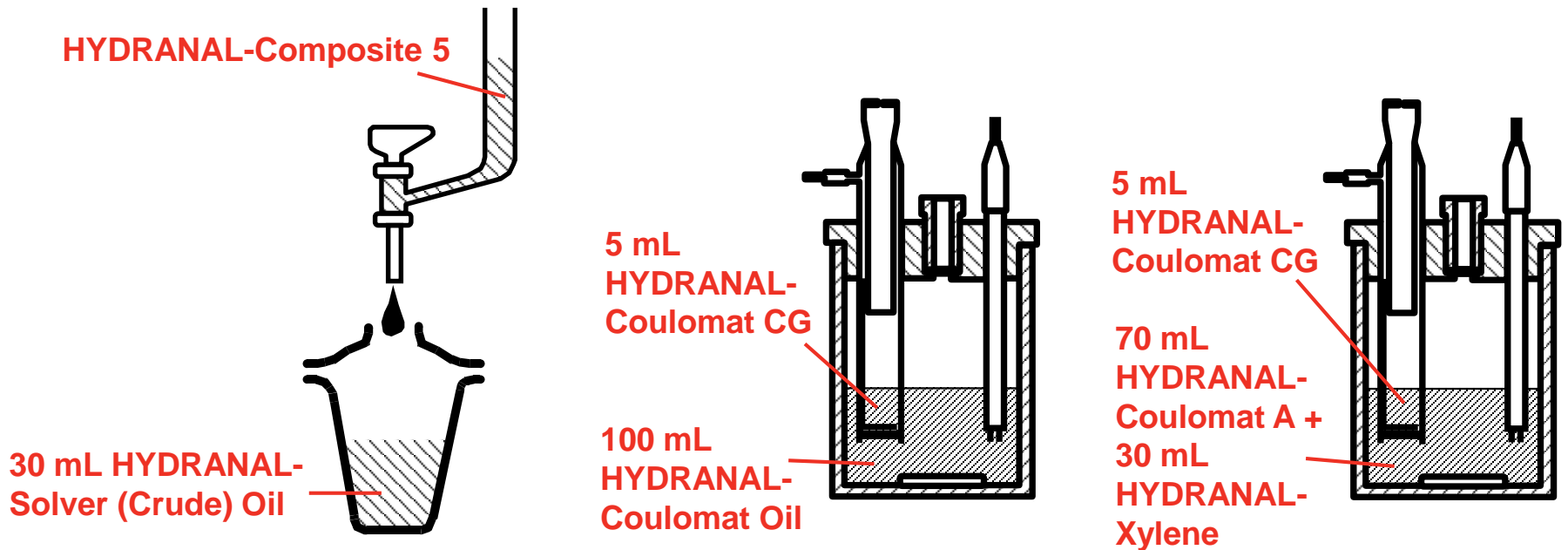

Application example: Kerosene (L 112)

- Low water content (few ppm) – only coulometric determination.
- Addition of **chloroform** is needed to improve the solubility of kerosene.
- **Procedure:**
 - Coulometric titration
 - Sample size: 1-5 mL

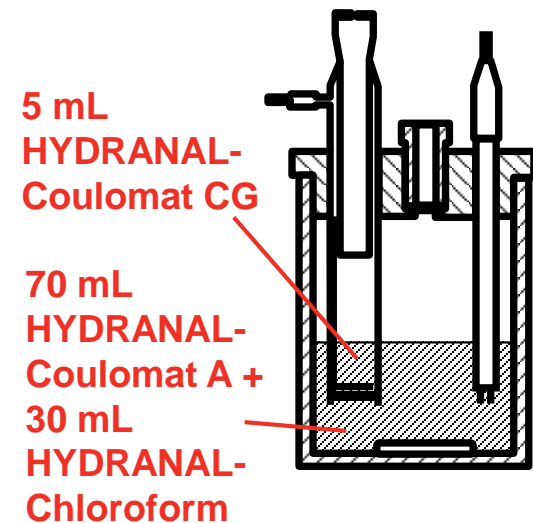
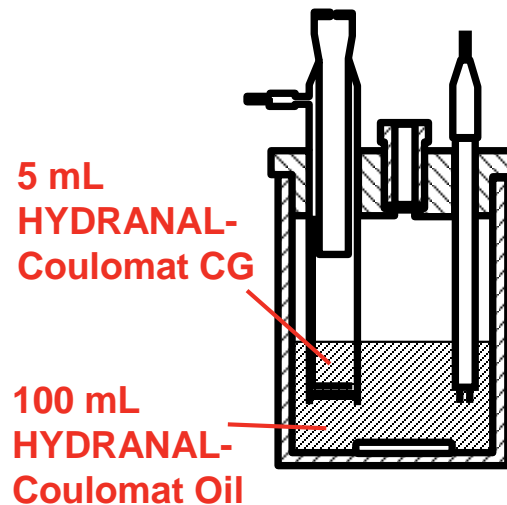

Application example: Silicon Oil (L 113)

- An additional solvent is necessary to dissolve the sample - **chloroform**.
- Due to the low water content of the material, large samples must be dissolved for a volumetric determination and for a coulometric determination many samples are added consecutively to the coulometric cell.
- **Procedure:**
 - One-component volumetric or coulometric titration
 - Sample size: 10 mL for volumetry, 1 mL for coulometry

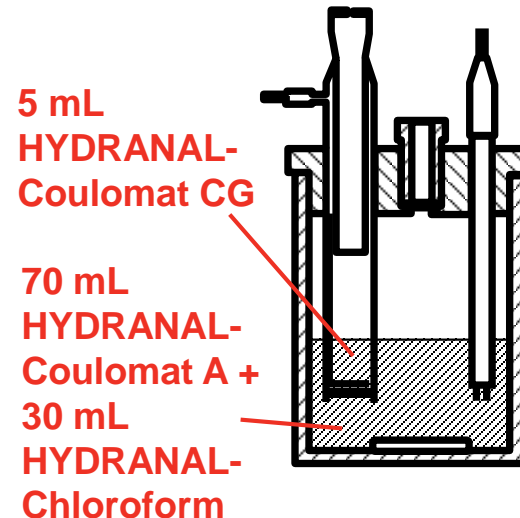
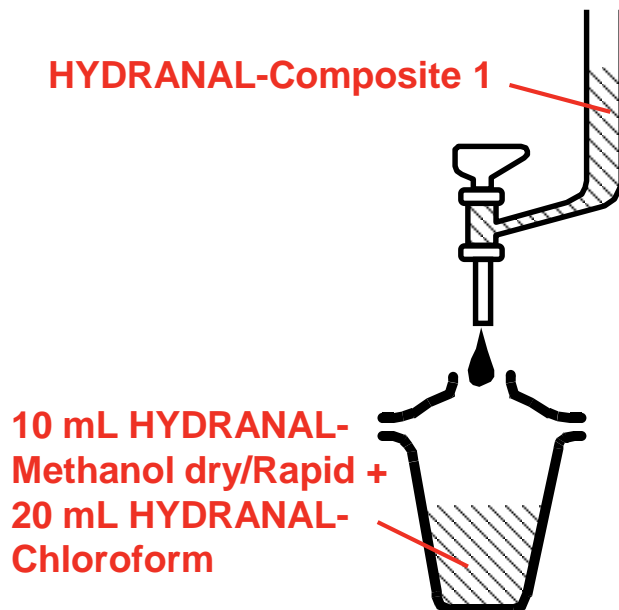

Application example: Engine Oil (L 201)

- The determination of water in engine oil is marked by the presence of very noticeable **side reaction**. Not only does a side reaction take place with methanol, but also with iodine. The side reaction occurs most strongly in a methanolic working medium. If a non-methanolic working medium is used, the reagent consumption is drastically reduced, yet a significant side reaction is still noticeable by the sluggish titration.
- **Procedure:**
 - Coulometric titration with **KF oven**
 - Sample size: 10 g (practical maximum: 2 g)

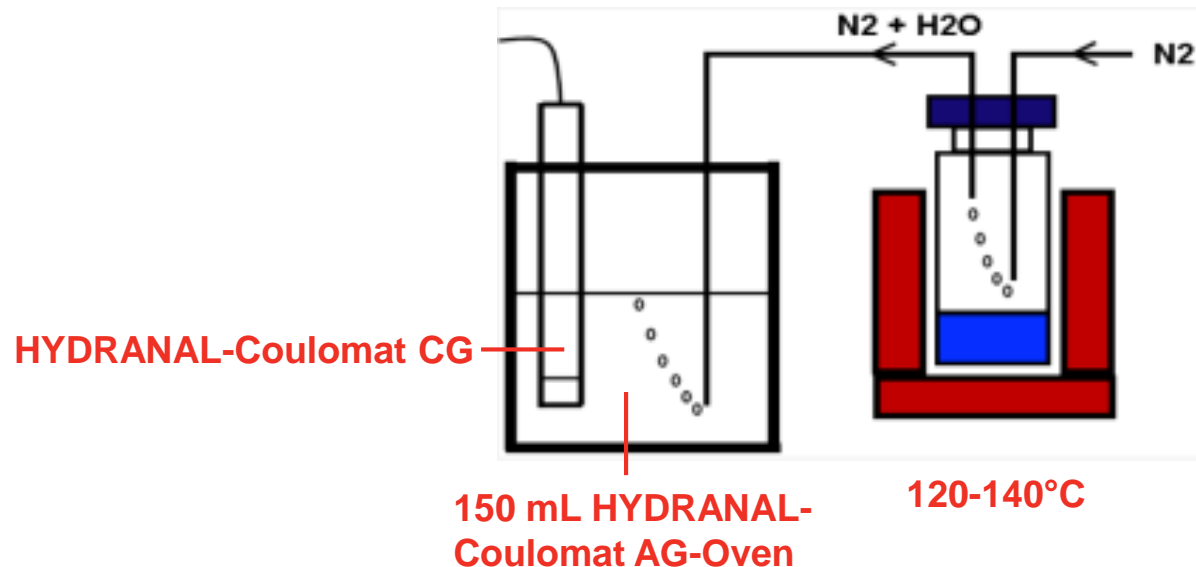

Application example: Petrol, unleaded (L 428)

- The **solubility** of petrol in the methanolic medium of the Karl Fischer titration is limited. **Ethanol-based reagents** are preferred for volumetric titrations because petrol dissolves well in them. 20 mL petrol dissolve in 30 mL Hydranal-CompoSolver E or Hydranal-Solvent E and 35 mL dissolve in 100 mL Hydranal-Coulomat E.
- Procedure:**
 - Volumetric or coulometric titration
 - Sample size: 10 mL for volumetry, 1-2 mL for coulometry

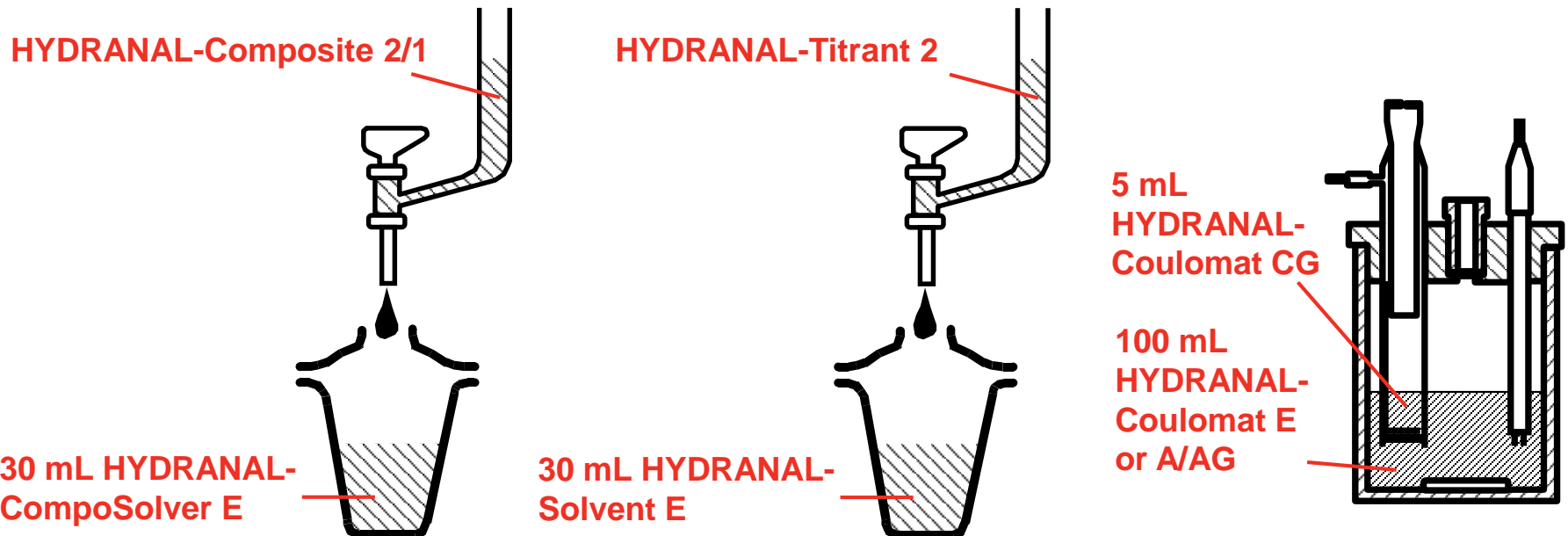

Applications: Chemical Industry



Application example: Cyanoacrylate Adhesive (L 118)

- Cyanoacrylate based adhesives form **lumps** in the alcohol solvents of the KF reagents. The alcohol must be complemented by a solubilizer, e.g. **chloroform**.
- The water content of those adhesives is very low. It is therefore important that the titration cell is adequately **very dry** before adding the first sample to the medium in the titration vessel.
- **Procedure:**
 - One-component volumetric titration
 - Sample size: 0.5 g

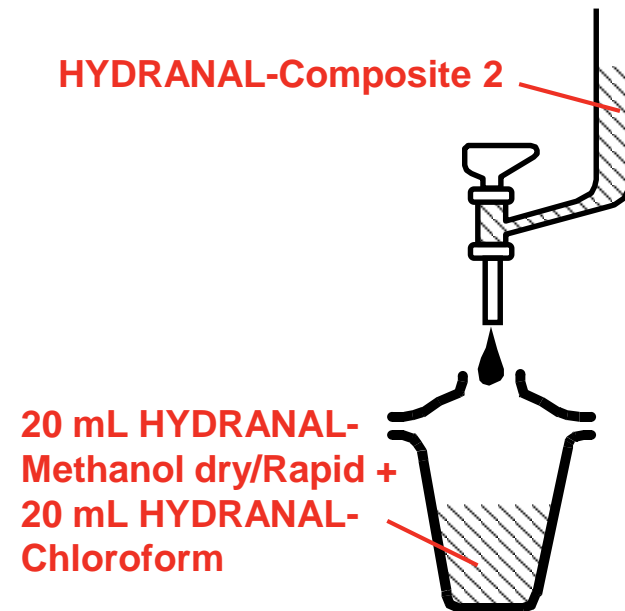
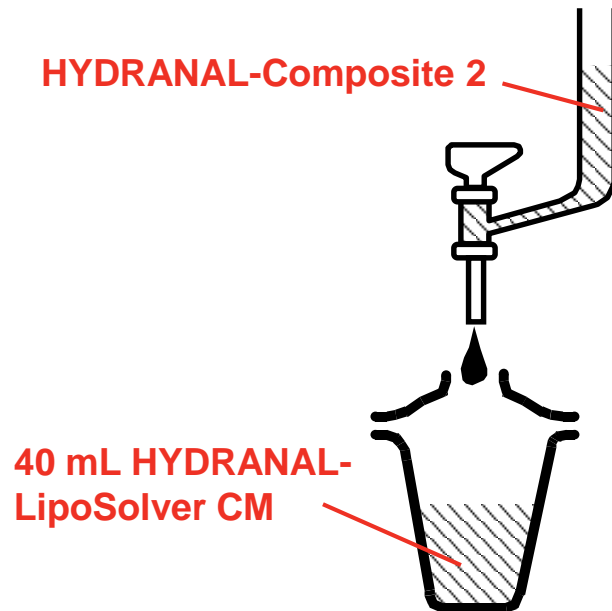

Application example: Expandable Polystyrene (L 691)

- Expandable polystyrene cannot be determined directly due to **poor solubility** in conventional KF media. This sample must be **dissolved externally** in a suitable solvent, then an aliquot of the solution can be determined in the Karl Fischer cell.
- **Procedure:**
 - One-component volumetric or coulometric titration
 - Sample preparation: 3 g sample in 50 mL chloroform, stirred 3 h
 - Sample size: 5 mL aliquot
 - KF oven with coulometer: 220°C in nitrogen. Adapt the size of the sample vessel for the anticipated sample expansion!

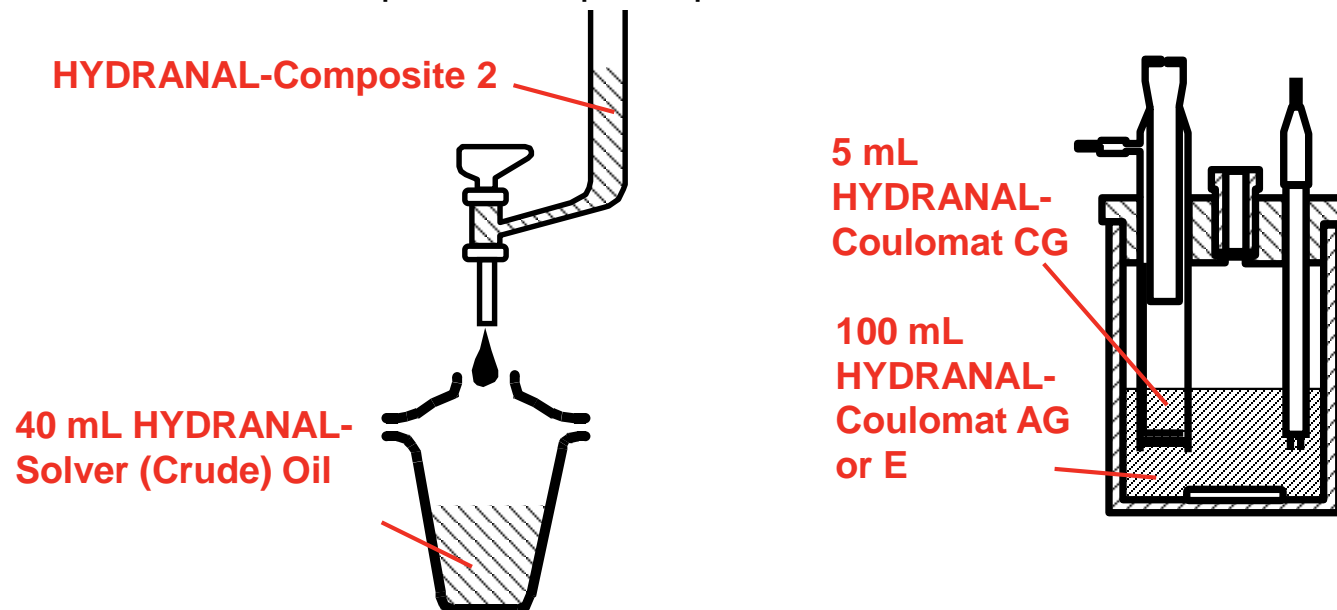

Application example: Polycarbonate (L 127, L 129)

- Due to its **poor solubility**, the indirect process with a **KF oven** should be preferred. Polycarbonate is only soluble in certain solvents and precipitates out as flakes from methanolic KF media on the electrodes. It is therefore necessary to carry out the titration using a **modified solvent**, but it takes 15 minutes for the sample to dissolve.
- **Procedure:**
 - One-component volumetric or coulometric titration with KF oven
 - Sample size: 2 g

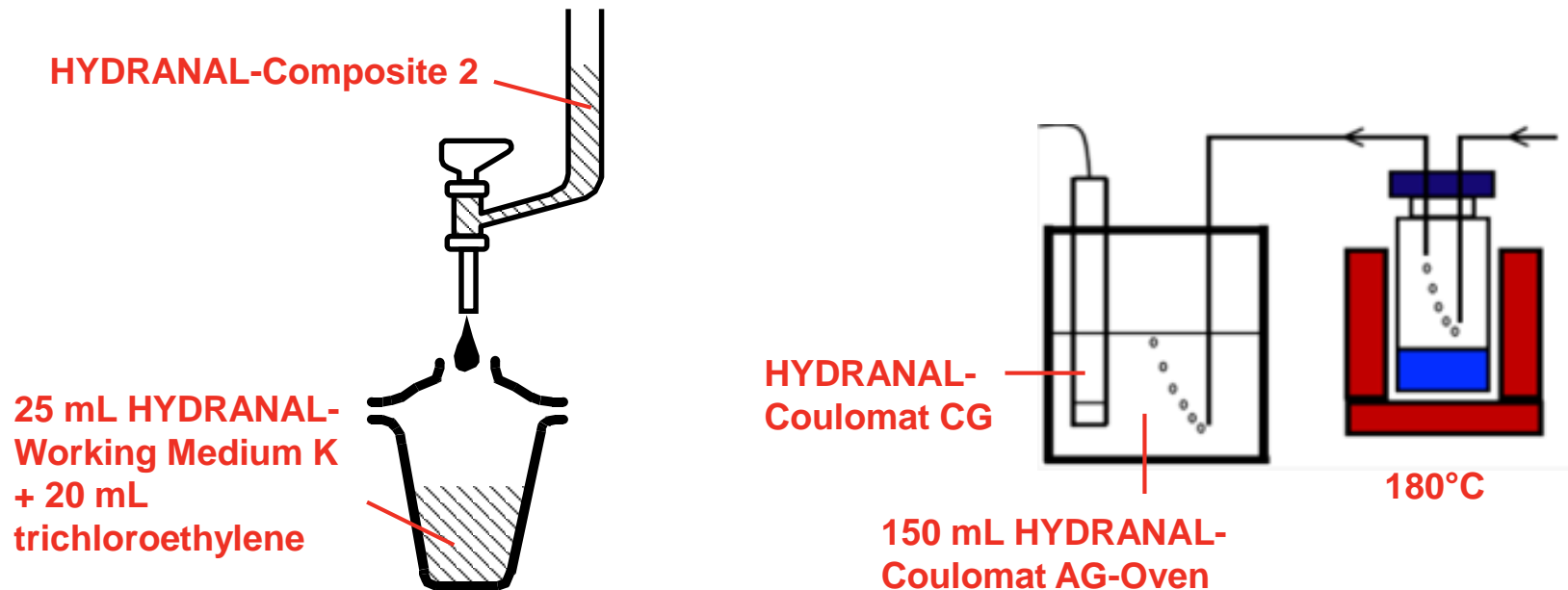

Application example: Poly-L-lactate, PLA (L 577)

- The granulate cannot be **dissolved** for direct titration in the alcohol-containing media of the KF reagents. This is true even when the media contain portions of chloroform.
- **Procedure:**
 - One-component volumetric or coulometric titration with KF oven
 - Sample preparation: 9 g sample in 50 mL **chloroform**, stir until dissolved to form a **viscous** solution
 - Sample size: 5 mL aliquot
 - Sample handling: disposable syringe without a needle
 - KF oven with coulometer: 210°C, 0.5 g sample

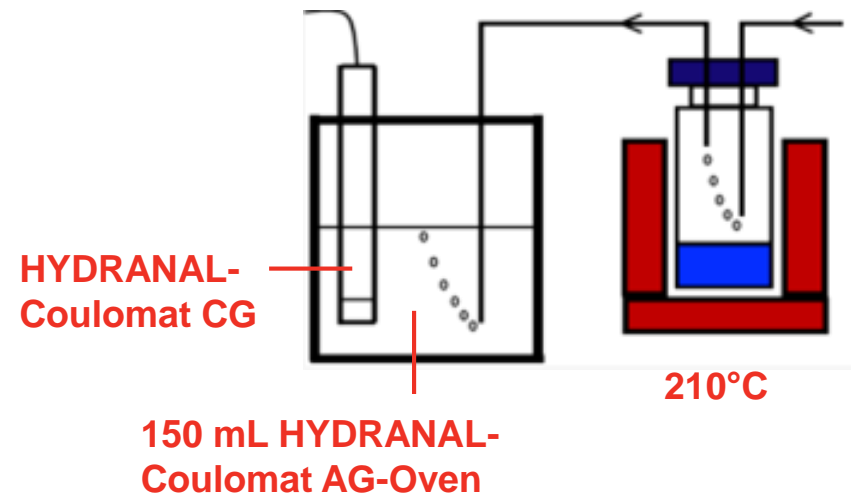
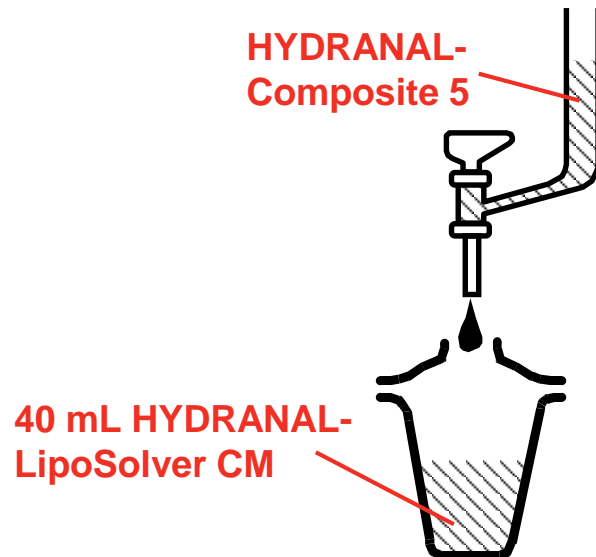

Application example: Caprolactone (L 410)

- A **side-reaction** is taking place. If the working medium in the titration vessel is changed for each new sample, the interference of the indication does not take place and a water content can be found reproducibly. Additionally, if the current is reduced from 50 μA to 10 μA , the indication interference occurs later. Since at **10 μA** current the titration proceeds much slower, the **accelerator** is added to the working medium.
- **Procedure:**
 - One-component volumetric or coulometric titration
 - Sample size: 10 g for volumetry; 5 g for coulometry (needed for reproducibility)

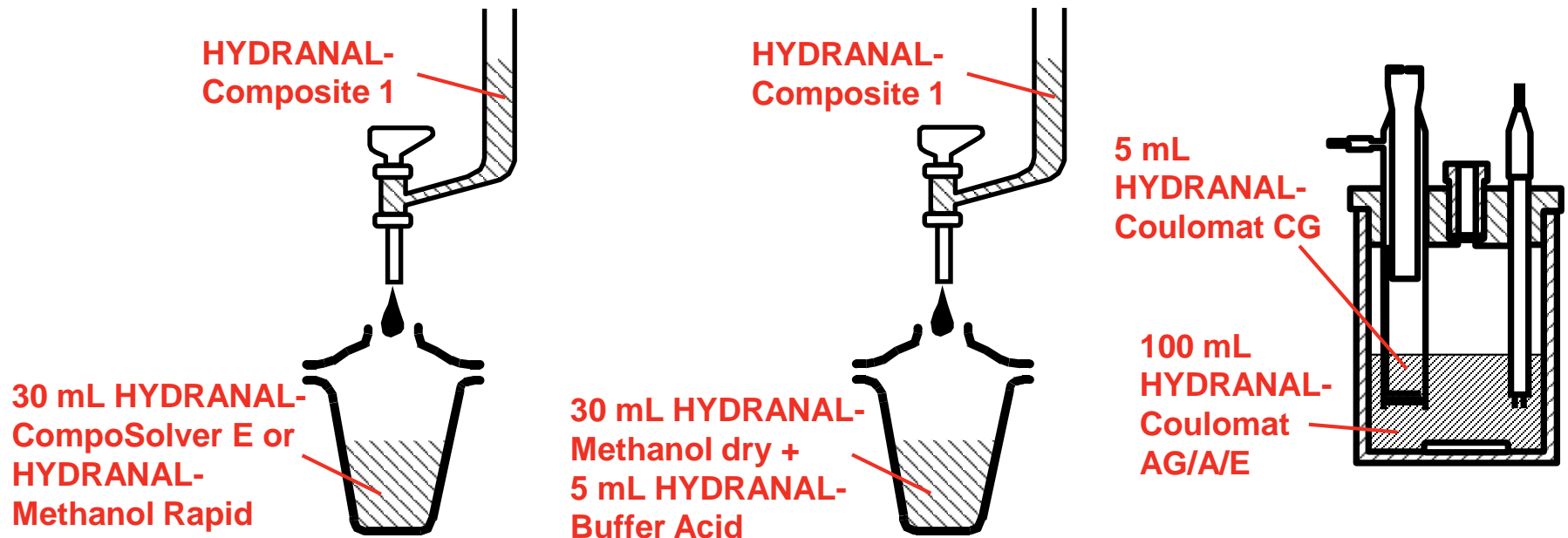

Applications: Food



Application example: Chocolate (L 071)

- Water determination in chocolate is trouble-free as long as the sample is dispersed quickly and homogeneously in the solvent. Therefore, methanol is not ideal as solvent. We recommend the addition of **chloroform** in order to dissolve fats. The addition of chloroform can be avoided if the titration is performed at **50°C**. Also, it is advisable to **fractionate** or grind the chocolate.

Procedure:

- One- or two-component volumetric titration
- Sample size: 1 g

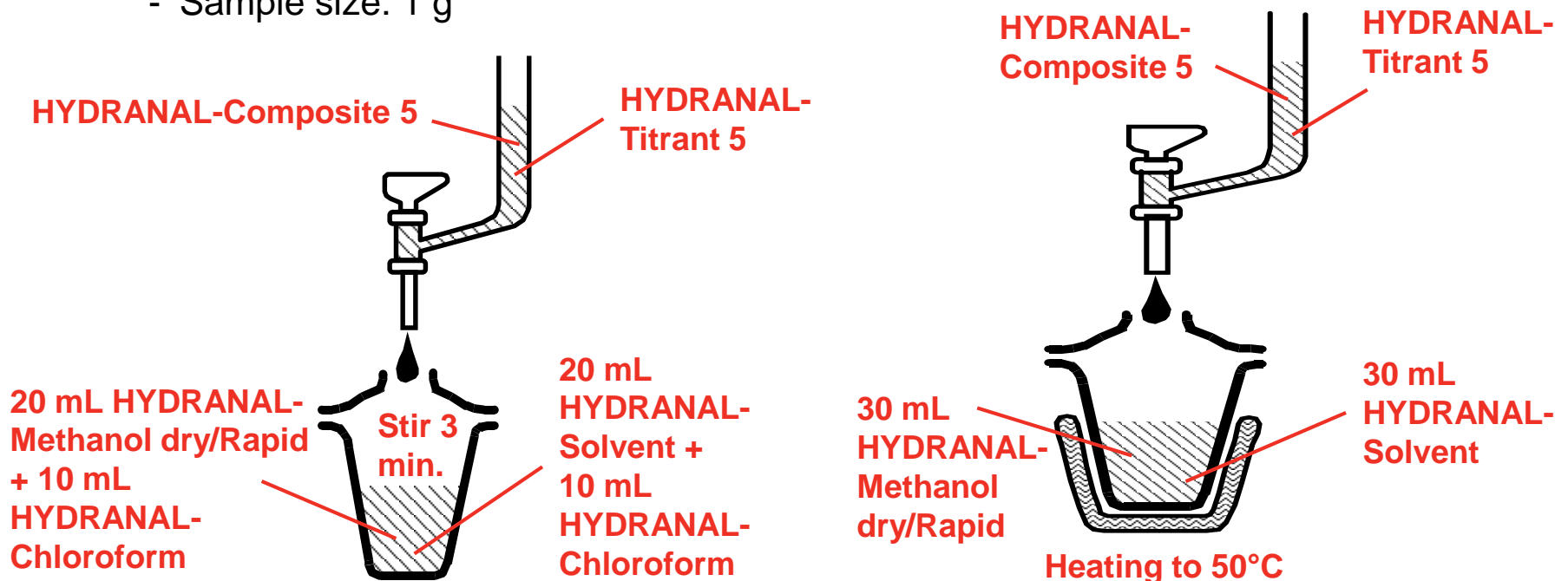

Application example: Butter (L 104)

- Butter is insoluble in methanol and **chloroform** is a suitable solubilizer. The sample has to be homogenized before analysis. The sample can be introduced directly by means of a **PTFE weighing spoon**, which remains in the solvent until the end of titration. The titration time is about 2 minutes. If a smaller amount of chloroform is used, the dissolving time is longer.

- **Procedure:**

- One- or two-component volumetric titration
- Sample size: 0.5 g

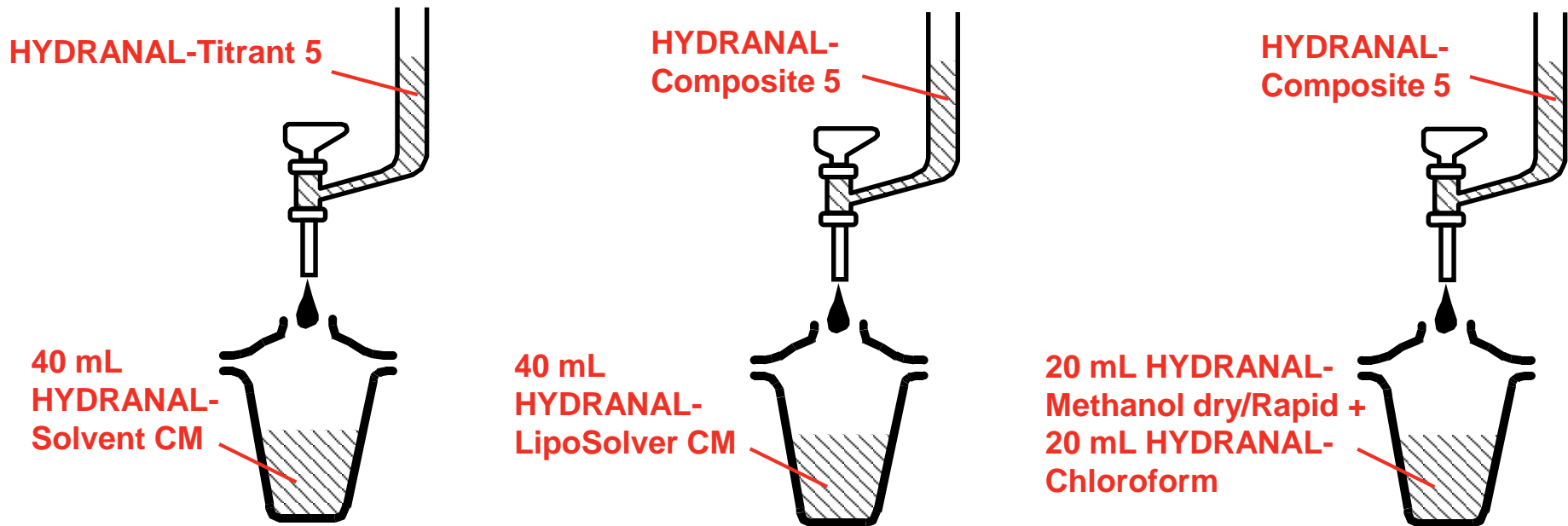

Application example: Yeast (L 384)

- Both fresh and dried yeast did not dissolve in the KF medium and they display differing problems in the extraction of the water.
- **Fresh yeast:** finely disperses gradually in the titration vessel during the titration. **Titration time** depends on solvent system used.
- **Procedure:**
 - One- or two-component volumetric titration
 - Sample size: 50-100 mg

	Two-component volumetric titration		One-component volumetric titration		
Titration agent	Hydranal-Titrant 5	Hydranal-Titrant 5 E	Hydranal-Composite 5	Hydranal-Composite 5	Hydranal-Composite 5
Working medium	30 mL Hydranal-Solvent	30 mL Hydranal-Solvent E	30 mL Hydranal-Methanol Dry	30 mL Hydranal-CompoSolver E	20 mL Hydranal-CompoSolver E + 10 mL Hydranal-Formamide dry
Titration time	1.5 min.	2.1 min.	5.3 min.	2 min.	< 2 min.

Application example: Yeast (L 384)

- **Dried yeast:** the surface of the fine granules is very hard, but should not be mechanically milled in the open air because it is extremely **hygroscopic**. Dry yeast releases its water content considerably **more slowly** and the determination times with the above reagents are up to 20 minutes under standard conditions.
- **Procedure:**
 - One-component volumetric titration at 50°C with homogenizer and addition of formamide → titration time 2 min.
 - External extraction:
40 g Hydranal-Methanol dry; 1.5 h
 - Titration with KF oven:
120°C, titration time 11 min.
 - Sample size: 2 g

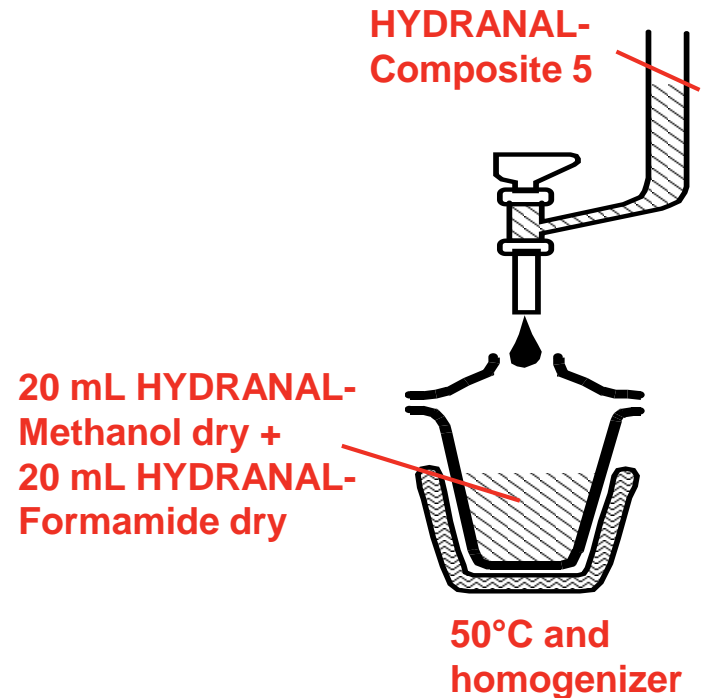

Application example: Instant Coffee (L 092)

- Three types of coffee: freeze dried, spray tower dried and agglomerated.
- They should be titrated in the presence of **formamide** to speed-up the water release.
- In each case to some degree a **side-reaction** takes place (oxidation by iodine, which is **pH dependant**). It can be suppressed by lowering the pH value of the working medium conditions with the addition of **salicylic acid** (to pH 3.2).
- **Procedure:**
 - One-component volumetric titration
 - Sample size: 0.5 g

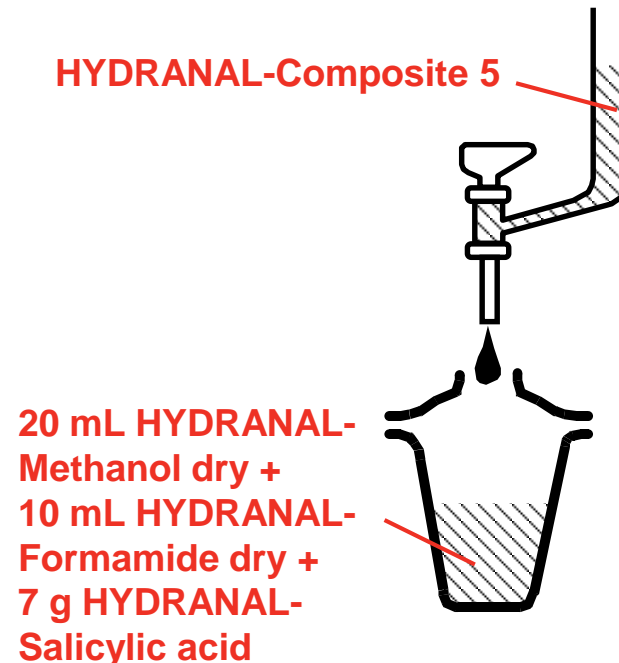

Application example: Ground Roast Coffee (L 178)

- It is difficult to **extract water** from natural products, like roast coffee, due to strong cellular bonds. Even at 50°C, the water contained in the coffee could not be satisfactorily extracted.
- Titration in **boiling methanol** is the method of choice for natural products.
- **Procedure:**
 - One-component volumetric titration in boiling methanol (with reflux condenser)
 - Sample size: 1 g

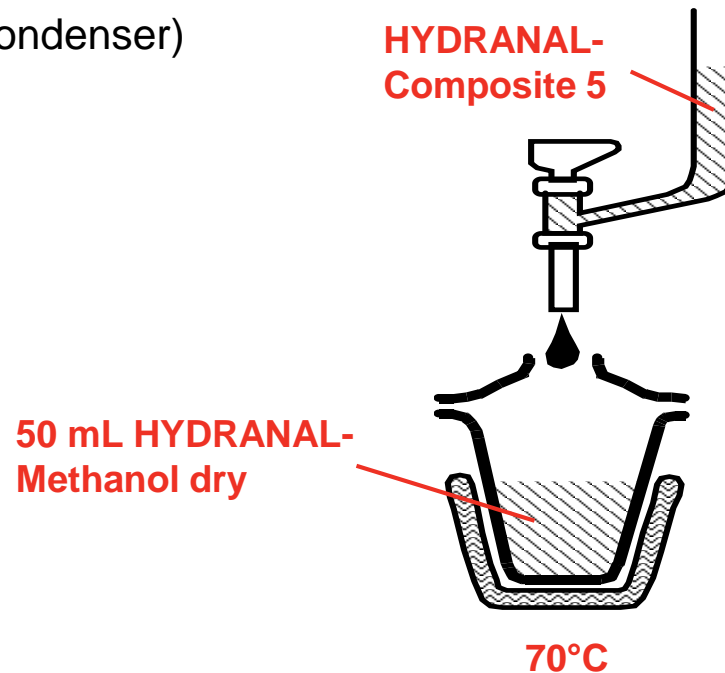

Closing: Literature and Support



HYDRANAL Literature

- HYDRANAL Product Overview Guide
- HYDRANAL Manual
- HYDRANAL Laboratory Reports
- HYDRANAL Pharmacopeia Suitability Tests Reports

www.hydranal-honeywell.com

www.lab-honeywell.com

HYDRANAL Starter Kits (free of charge)

Coulometric Reagents

34744 Hydranal Sample Box Coulometry AG/CG

Coulomat AG (250 mL), Coulomat CG (3*5 mL) and Water Standard 1.0 (3*4 mL)

37994 Hydranal Sample Box Coulomat Oil

Coulomat Oil (250 mL), Coulomat CG (3*5 mL) and Water Standard 1.0 (3*4 mL)

34423 Hydranal Sample Box Coulometry AG Oven

Coulomat AG Oven (250 mL), Coulomat CG (3*5 mL), Water Standard 1.0 (3*4 mL) and Water Standard KF Oven 140-160°C (1 g)

Volumetric One-Component Reagents

37997 Hydranal Sample Box Volumetry Composite 5/Methanol Rapid

Composite 5 (500 mL), Methanol Rapid (500 mL) and Water Standard 10.0 (3*8 mL)

Volumetric Two-Component Reagents

34728 Hydranal Sample Box Volumetry Titrant/Solvent

Titrant 5 (500 mL), Solvent (500 mL) and Water Standard 10.0 (3*8 mL)

Water Standards

34849-SAMPLE Hydranal Water Standard 10.0 (3*8 mL)

34828-SAMPLE Hydranal Water Standard 1.0 (3*4 mL)

34446-SAMPLE Hydranal Water Standard 0.1 PC (3*4 mL)

**Check the ordering
process for your
country**



Dedicated HYDRANAL Support

hydranal@honeywell.com

for all technical questions



Europe and Global Market
Thomas Wendt
HYDRANAL Technical Service
Seelze, Germany
Tel. +49 (0) 5137 8238-353
E-Mail:
Thomas.Wendt@Honeywell.com



Europe and Global Market
Agnieszka Kossakowska
HYDRANAL Technical Specialist
Warsaw, Poland
Mobile: +48 512 355 628
E-Mail:
Agnieszka.Kossakowska@Honeywell.com



USA and Canada
Doug Clark
HYDRANAL Technical Center
St. Louis, MO
Toll free +1 800 493-7262
E-Mail:
Douglas.Clark@Honeywell.com

Děkuji!

